

## Trademarks

LAUNCH is a registered trademark of LAUNCH TECH CO., LTD. in China and other countries. All other marks are trademarks or registered trademarks of their respective holders.

## Copyright Information

Copyright © 2024 by LAUNCH TECH CO., LTD. (also called LAUNCH for short). All rights reserved. No part of this publication may be reproduced, stored in a retrieval system, or transmitted in any form or by any means, electronic, mechanical, photocopying and recording or otherwise, without the prior written permission.

Statement: LAUNCH owns the complete intellectual property rights for the software used by this product. For any reverse engineering or cracking actions against the software, LAUNCH will block the use of this product and reserve the right to pursue their legal liabilities.

## Disclaimer of Warranties and Limitation of Liabilities

All information, illustrations, and specifications in this manual are based on the latest information available at the time of publication.

The right is reserved to make changes at any time without notice. We shall not be liable for any direct, special, incidental, indirect damages or any economic consequential damages (including the loss of profits) due to the use of the document.

## Using This Manual

This manual contains device usage instructions.

Some illustrations shown in this manual may contain modules and optional equipment that are not included in your system.

The following conventions are used.

### Bold Text

Bold text is used to highlight selectable items such as buttons and menu options.

### Example:

Tap **OK**.

### Notes

A NOTE provides helpful information such as additional explanations, tips, and comments.

### Example:

 Note: Remember to remove the VCI connector from the vehicle's DLC after use.

### Warning

Warning indicates a hazardous situation which, if not avoided, could result in minor or moderate injury to the operator or to bystanders.

### Example:

 Warning: Retrieving and using DTCs for troubleshooting vehicle operation is only one part of an overall diagnostic strategy. Never replace a part based only on the DTC definition. Each DTC has a set of testing procedures, instructions and flow charts that must be followed to confirm the location of the problem. This information can be found in the vehicle's service manual.

### Danger

Danger indicates an imminently or potentially hazardous situation which, if not avoided, could result in death or serious injury to the operator or to bystanders.

### Example:

 Danger: If you must drive the vehicle in order to perform a troubleshooting procedure, always have a second person help you. Trying to drive and operate the diagnostic tool at the same time is dangerous, and could cause a serious traffic accident.

### Illustrations

Illustrations used in this manual are samples, the actual testing screen may vary for each vehicle being tested. Observe the menu titles and on-screen instructions to make correct option selection.

### Important Safety Precautions

To avoid personal injury, property damage, or accidental damage to the product, read all of the information in this section before using the product.

#### **DANGER**

- When an engine is operating, keep the service area well-ventilated or attach a building exhaust removal system to the engine exhaust system. Engines produce various poisonous compounds (hydrocarbon, carbon monoxide, nitrogen oxides, etc.) that cause slower reaction time and result in death or serious personal injury.
- Please use the included battery and power adaptor. Risk of explosion if the battery is replaced with an incorrect type.
- If you must drive the vehicle in order to perform a troubleshooting procedure, always have a second person help you. Trying to drive and operate the diagnostic tool at the same time is dangerous, and could cause a serious traffic accident.

#### **WARNING**

- Always perform automotive testing in a safe environment.
- Do not connect or disconnect any test equipment while the ignition is on or the engine is running.
- Before starting the engine, put the gear lever in the Neutral position (for manual transmission) or in the Park (for automatic transmission) position to avoid injury.
- NEVER smoke or allow a spark or flame in vicinity of battery or engine. Do not operate the tool in explosive atmospheres, such as in the presence of flammable liquids, gases, or heavy dust.
- Keep a fire extinguisher suitable for gasoline/chemical/electrical fires nearby.
- Wear an ANSI-approved eye shield when testing or repairing vehicles.
- Put blocks in front of the drive wheels and never leave the vehicle unattended while testing.
- Use extreme caution when working around the ignition coil, distributor cap, ignition wires and spark plugs. These components create hazardous voltage when the engine is running.
- To avoid damaging the tool or generating false data, please make sure the vehicle battery is fully charged and the connection to the vehicle DLC (Data Link Connector) is clear and secure.
- Retrieving and using DTCs for troubleshooting vehicle operation is only one part of an overall diagnostic strategy. Never replace a part based only on the DTC definition. Each DTC has a set of testing procedures, instructions and flow charts that must be followed to confirm the location of the problem. This information can be found in the vehicle's service manual.
- Automotive batteries contain sulfuric acid that is harmful to skin. In operation, direct contact with the automotive batteries should be avoided. Keep the ignition sources away from the battery at all times.
- Keep the tool dry, clean, free from oil, water or grease. Use a mild detergent on a clean cloth to clear the outside of the equipment when necessary.
- Keep clothing, hair, hands, tools, test equipment, etc. away from all moving or hot engine parts.
- Store the tool and accessories in a locked area out of the reach of children.
- Do not use the tool while standing in water.
- Do not expose the tool or power adaptor to rain or wet conditions. Water entering the tool or power adaptor increases the risk of electric shock.
- This tool is a sealed unit. There are no end-user serviceable parts inside. All internal repairs must be done by an authorized repair facility or qualified technician. If there is any inquiry, please contact the dealer.
- Keep the tool far away from magnetic devices because its radiations can damage the screen and erase the data stored on the tool.

- Do not attempt to replace the internal rechargeable lithium battery. Contact the dealer for factory replacement.
- Do not disconnect battery or any wiring cables in the vehicle when the ignition switch is on, as this could avoid damage to the sensors or the ECU.
- Do not place any magnetic objects near the ECU. Disconnect the power supply to the ECU before performing any welding operations on the vehicle.
- Use extreme caution when performing any operations near the ECU or sensors. Ground yourself when you disassemble PROM, otherwise ECU and sensors can be damaged by static electricity.
- When reconnecting the ECU harness connector, be sure it is attached firmly, otherwise electronic elements, such as ICs inside the ECU, can be damaged.

## **FCC Statement**

FCC ID: XUJOADDPD1302

Note: This equipment has been tested and found to comply with the limits for a Class B digital device, pursuant to part 15 of the FCC Rules. These limits are designed to provide reasonable protection against harmful interference in a residential installation. This equipment generates, uses and can radiate radio frequency energy and, if not installed and used in accordance with the instructions, may cause harmful interference to radio communications. However, there is no guarantee that interference will not occur in a particular installation. If this equipment does cause harmful interference to radio or television reception, which can be determined by turning the equipment off and on, the user is encouraged to try to correct the interference by one or more of the following measures:

- Reorient or relocate the receiving antenna.
- Increase the separation between the equipment and receiver.
- Connect the equipment into an outlet on a circuit different from that to which the receiver is connected.
- Consult the dealer or an experienced radio/TV technician for help.

The device has been evaluated to meet general RF exposure requirement. The highest reported SAR for stand-alone and simultaneous transmission exposure conditions are below the maximum value. End-users must be informed of the operating requirements for satisfying RF exposure compliance.

This device is in compliance with the essential requirements and other relevant provisions of Radio Equipment Directive 2014/53/EU. The RF frequencies can be used in Europe without restriction.

**TABLE OF CONTENTS**

<b>1 Introduction</b> .....	<b>1</b>
1.1 Product Profile.....	1
1.2 Package List.....	1
1.3 Components & Controls .....	2
1.3.1 Diagnostic Tablet .....	2
1.3.2 VCI .....	3
1.4 Technical Specifications.....	4
<b>2 Initial Setup</b> .....	<b>6</b>
2.1 Charging & Powering On .....	6
2.2 Screen Layout .....	6
2.3 Adjusting Screen Brightness .....	6
2.4 Changing Language .....	6
2.5 Network Setup.....	6
<b>3 Register &amp; Update</b> .....	<b>8</b>
3.1 Register & Update.....	8
3.2 Home Screen .....	10
<b>4 Connections</b> .....	<b>11</b>
4.1 Preparation.....	11
4.2 Vehicle Connection .....	11
4.3 Communication Setup.....	12
<b>5 Diagnosis</b> .....	<b>13</b>
5.1 Intelligent Diagnose.....	13
5.2 Local Diagnose .....	15
5.3 Remote Diagnose .....	21
5.3.1 SmartLink super remote diagnostics.....	21
5.3.2 X431 remote diagnostics.....	23
5.4 EV (Electric Vehicle) Diagnose .....	28
5.4.1 Vehicle Diagnosis.....	28
5.4.2 Battery Pack Detection.....	28
5.5 Diagnostic History .....	30
5.6 Feedback .....	30
<b>6 Service Function</b> .....	<b>31</b>
<b>7 Software Update</b> .....	<b>32</b>
7.1 Update Diagnostic Software & APP.....	32
7.2 Update Frequently Used software.....	32
7.3 Renew Subscription .....	32
<b>8 Toolbox</b> .....	<b>33</b>
8.1 TPMS .....	33
8.2 ADAS (Calibration).....	33
8.3 Oscilloscope.....	33
8.4 Sensor Simulator.....	33
8.5 BST360 (Battery Tester) .....	33
8.6 Immobilizer Programmer.....	33
8.7 Videoscope .....	33
8.8 Current Clamp.....	34
8.9 Insulation Tester.....	34
8.10 Multimeter .....	34

8.11 Key Programmer .....	34
<b>9 Diagnostic Widget.....</b>	<b>35</b>
9.1 Vehicle Coverage .....	35
9.2 CAN Bus Pin Detection .....	35
9.3 CANScope .....	35
9.4 Diagnostic Software Clear.....	35
9.5 Fix Connector Firmware/System.....	35
9.6 Data Stream Sample.....	35
9.7 DLC Voltage Check.....	35
9.8 Reset MSVIN .....	35
<b>10 User Info.....</b>	<b>36</b>
10.1 My Report.....	36
10.2 VCI .....	37
10.3 Activate VCI .....	37
10.4 Profile .....	37
10.5 My Order .....	37
10.6 Change Password.....	37
10.7 Login/Log out .....	37
<b>11 Settings .....</b>	<b>38</b>
11.1 Units of measurement .....	38
11.2 Shop information .....	38
11.3 Printer set.....	38
11.4 Clear cache .....	39
11.5 About.....	39
11.6 Diagnostic software auto update.....	39
11.7 Device account management.....	39
<b>12 J2534 Reprogramming Using SmartLink C .....</b>	<b>41</b>
<b>13 FAQ.....</b>	<b>42</b>
13.1 About diagnostic tablet.....	42
13.2 About SmartLink Diag .....	43



# 1 Introduction

## 1.1 Product Profile

This Android OS-based, tablet-style diagnostic tool incorporates the best possible coverage of OE-level diagnostics with multitasking capable software.

Using the powerful Octa-core 2GHz processor, 12G RAM, and a 13.6" IPS capacitive touch screen with a resolution of 2560 x 1600 dots, it delivers quick and complete diagnostic functionalities which technicians need to diagnose, research and repair vehicles in one solution.

It has the following features: Intelligent Diagnose, Local Diagnose, EV (Electric Vehicle) Diagnose & Service, SmartLink Super Remote Diagnose, X431 Remote Diagnose, Service Function, Toolbox, Software Update, Feedback, Online Mall and Diagnostic History etc.

## 1.2 Package List

Common accessories are same, but for different destinations, the accessories may vary. For detailed accessory items, please consult from the seller or check the packing list supplied with this tool together.

No.	Item	Description	Qt.
1	Diagnostic tablet	Indicate the test results.	1
2	SmartLink C V3.0 VCI device	Connect to vehicle's DLC (Data Link Connector) port to access vehicle's live data.	1
3	Diagnostic cable	Connect the VCI to vehicle's DLC port. It can be separated into two parts: DB15F to HD15F data cable and HD15M to OBD16 adaptor.	1
4	Power adaptors	Charge the display tablet.	4
5	Type A to Type B data cable	Connect the VCI to the tablet to perform vehicle diagnosis.	1
6	Type A to Type C data cable	Connect the VCI to the PC for data exchange.	1
7	Password envelope	A piece of paper bearing Product S/N and Activation Code, which is needed for product registration.	1
8	Crossover cable	Connect the VCI device to the modem when performing SmartLink Super Remote Diagnostics.	1
9	Mini-HDMI to HDMI cable	Connect to an external projector or monitor with HDMI interface.	1
10	Quick start guide		1
11	Non-16pin adaptor kit for passenger cars	For different vehicle diagnostic socket, it may be necessary to use one of the non-16pin connectors included within the kit. For detailed non-16pin connectors, please check the package box.	(optional)

## 1.3 Components & Controls

There are two main components to the diagnostic system:

- Diagnostic Tablet – the central processor and monitor for the system (See Chapter 1.3.1).
- VCI (Vehicle Communication Interface) – the device for accessing vehicle data (See Chapter 1.3.2).

### 1.3.1 Diagnostic Tablet

The tablet acts as the central processing system, which is used to receive and analyze the live vehicle data from the SmartLink C device and then output the test result.

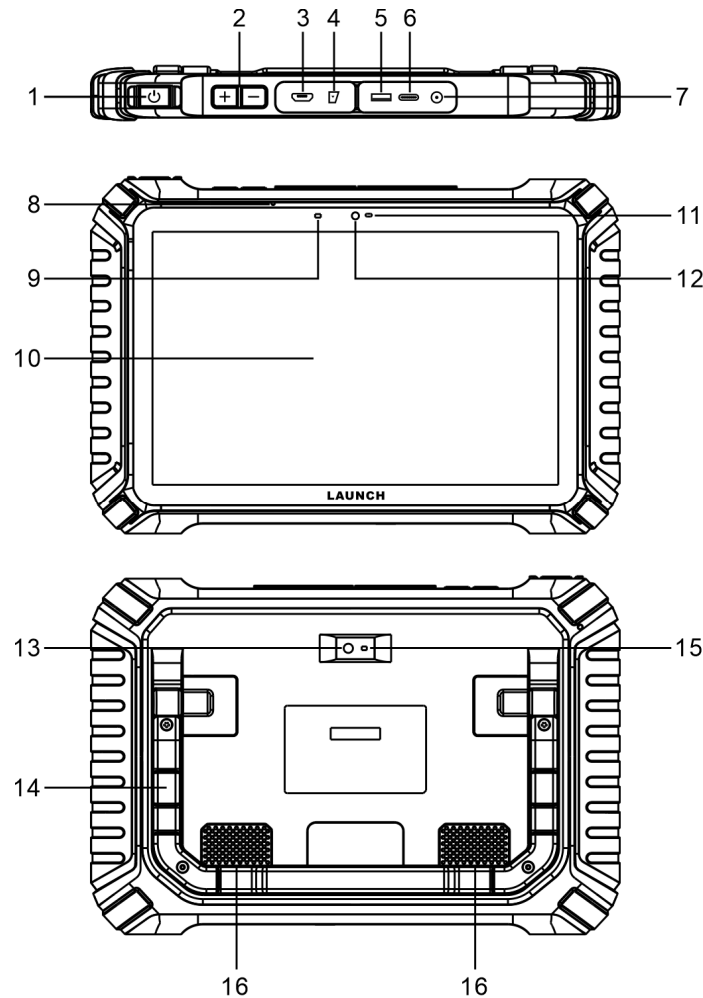

#### 1. Power/Screen Lock Button

Turn the tablet on/off with long press, or lock the screen with short press.

#### 2. Volume Buttons

Adjust the volume.

#### 3. High Definition Multimedia Output Port

Connect to an external projector or monitor.

#### 4. Memory Card Slot

Store the memory card for storage expansion.

#### 5. Data Transmission Port

Reserved for add-on modules, and other USB devices use only.

#### 6. Type-C Charging Port



Reserved for charging or transferring data.

#### 7. DC IN Port

Connect the power adaptor to charge the tablet.

#### 8. Microphone

#### 9. Charging indicator

It illuminates red while the tablet is charging. Once charging is finished, it will illuminate solid green.

#### 10. Touch Screen

#### 11. Ambient Light Sensor

#### 12. Front Camera

#### 13. Rear Camera

#### 14. Adjustable Kickstand

Flip out it to any angle and work comfortable at your desk, or hang it on automotive part.

#### 15. Camera Flash

#### 16. Audio Speaker

### 1.3.2 VCI

The SmartLink C V3.0 device features powerful functions and it can be applied in the following situations:

- 1). When as a VCI (Vehicle Communication Interface), it needs to work in conjunction with the **Diagnose** module of the tablet, which is used to obtain vehicle data, and then send it to the tablet for analysis wirelessly or via data cable.
- 2). When as a SmartLink C (Customer) dongle, it does not communicate with the tablet, but it needs to work together with the **SmartLink** module of the tablet. The tablet is mainly used to issue remote diagnostic requests, and the SmartLink C dongle is networked to receive and execute commands from the remote SmartLink B (Business).

 Note: For detailed operations, please refer to Chapter 5.3.1.

- 3). When as a local J2534 PassThru device, it can be used in conjunction with the PC installed with OEM diagnostic software.

 Note: For detailed operations, please refer to Chapter 12.

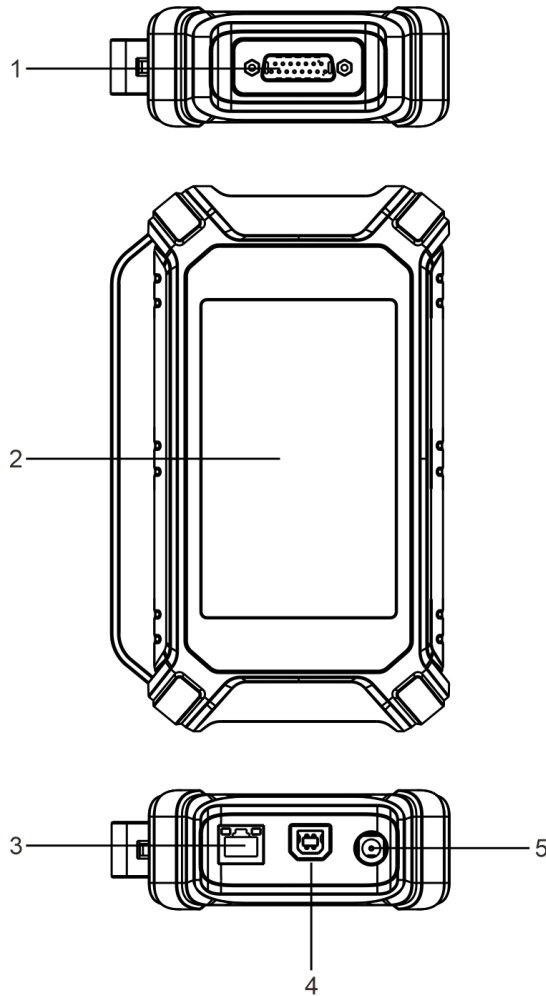

**1. DB-15 diagnostic connector**

Connect it to the vehicle's DLC (Data Link Connector) port via the diagnostic cable.

**2. Touch screen**

**3. LAN/WAN port**

Connect it to the modem via the crossover cable. It only applies to the SmartLink Super Remote Diagnostics.

**4. Data I/O port**

- Connect it to the tablet to perform vehicle diagnosis.
- Connect it to the PC to perform J2534 reprogramming when as a J2534 PassThru device.

**5. DC-IN power jack**

It can obtain power via connecting the diagnostic cable to the vehicle's DLC port or connecting to an external DC power supply.

**⚠ Warning:** The SmartLink C V3.0 device obtains power through the vehicle's DLC via the DB-15 diagnostic connector. **DO NOT** connect this power jack to an external DC power supply when the SmartLink C V3.0 device is properly connected to the vehicle's DLC port. No responsibility can be assumed for any damage or loss caused as a result of not strictly following the warning.

## **1.4 Technical Specifications**

### **1. Display tablet**

Operating system: Android

CPU: Octa-core processor, 2.0GHz

Display: 13.6 inch IPS capacitive touch screen with 2560 x 1600 resolution

Memory: 12GB

Hard disk: 512GB

Connectivity:

- Wi-Fi: 2.4G/5GHz dual frequency
- Universal serial BUS ports (1 x Type-C + 1 x Type-A)

Camera: front-facing 8MP + 20MP rear-facing camera (Auto focus)

HDMI: MicroHDMI out

Operating Temperature: 0°C ~ 50°C

Storage Temperature: -20°C ~ 70°C

## **2. VCI (Vehicle Communication Interface)**

Display: 3.95 inch TFT screen with 320 x 480 resolution

Working voltage: DC 9~36V

Communication: wireless and wired

Size: 197mm x 108mm x 43mm

Working temperature: 0°C~ 50°C

## 2 Initial Setup

### 2.1 Charging & Powering On

 Notes:

- Only use the included power adaptor to recharge the tablet. Use of any other adaptor will damage the tool. We assume no responsibility for damage or loss resulting from using other similar adaptors other than the specified one.
- Always charge on a non-flammable surface in a well-ventilated area.

To check the battery power level, press and hold the Power button about 3 seconds to turn on the tablet. Power level is indicated as a percentage in the upper right corner of the screen. If the power level drops below 10% while the tablet is on, a “Connect Charger” notification will appear on the screen.

1. Connect one end of the power adaptor to the DC IN port of the tablet, and the other end to the AC outlet.
2. The charging LED illuminates solid red and the charging symbol will appear on the screen.
3. Once it illuminates solid green, it indicates that the battery is fully charged and the charging complete symbol  replaces the charging symbol. Disconnect the power adaptor from the AC outlet.
4. Press and hold the **POWER** button for about 3 seconds to turn on the tablet. The system starts initializing and then enters the home screen.

To turn the tablet off, press and hold the **POWER** button until an option menu appears. Tap **Power Off**.

### 2.2 Screen Layout

On-screen keys and status bar on the bottom of the screen are as follows:

Tap  to return to the previous screen or exit the application.

Tap  to jump to the home screen.

Tap  to display a list of applications that are currently running or recently used.

Tap  to capture the current screen and all captured screenshots are stored in the Screenshots folder.

 shows whether the VCI is connected properly or not.

### 2.3 Adjusting Screen Brightness

The tablet is equipped with a built-in light intensity sensor. It can adjust the screen brightness according to the ambient light intensity automatically. Alternatively, you can also adjust it manually.

1. On the home screen, tap **Settings -> Display -> Brightness level**.
2. Drag the slider to adjust it.

Alternatively, user may also slide the **Automatically brightness** switch to ON, and the system will automatically adjust the screen brightness.

 Note: Reducing the brightness of the screen is helpful to save the power of the tablet.

### 2.4 Changing Language

The tablet supports multiple languages. To change the language of the tablet, please do the following:

1. On the home screen, tap **Settings -> System -> Language & input -> Languages**.
2. Tap the desired language from the list and the system will change to the chosen language.

### 2.5 Network Setup

The tablet has built-in Wi-Fi that can be used to get online. Once you're online, you can register the tablet, browse the

Internet, get and update apps on your network.

 Note: Once WLAN is set as ON, the tablet will consume more power. While WLAN keeps unused, please turn it off to conserve battery power.

1. On the home screen, tap **Settings -> Network & internet -> Internet -> Wi-Fi**.
2. Tap or slide the Wi-Fi switch to ON, the tablet starts searching for all available wireless LANs.
3. Choose the desired Wi-Fi access point / network,
  - If the network you chose is open, you can connect directly.
  - If the selected network is encrypted, you have to enter the right security key (network password).

When this tool is in range, it will connect to the previously linked network automatically.

### 3 Register & Update

For new users, you will need to experience a user registration process before getting started.

#### 3.1 Register & Update

After the tablet is initialized, tap the **Login** button on the upper right corner of the screen, the following screen will appear:

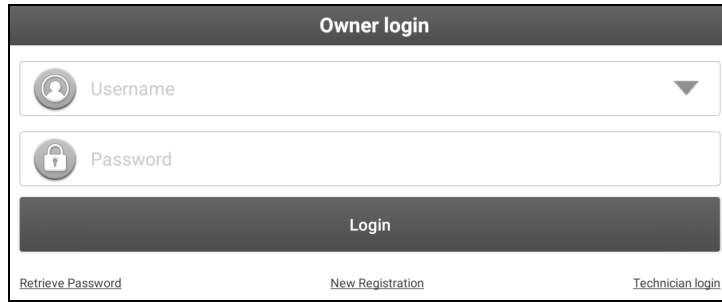

(If you are a new user, follow **A** to proceed.)

(If you have registered to be a member, go to **B** to login the system directly.)

(If you have bound a sub-account to this tool, go to **C** to login the system.)

(In case you forgot password, refer to **D** to reset a new password.)

A.If you are a new user, tap **New Registration** to enter sign-up page.

1. Create an App Account: Input the information to create a new account (all fields must be completed). When finished tap **Register**, the following screen will appear:

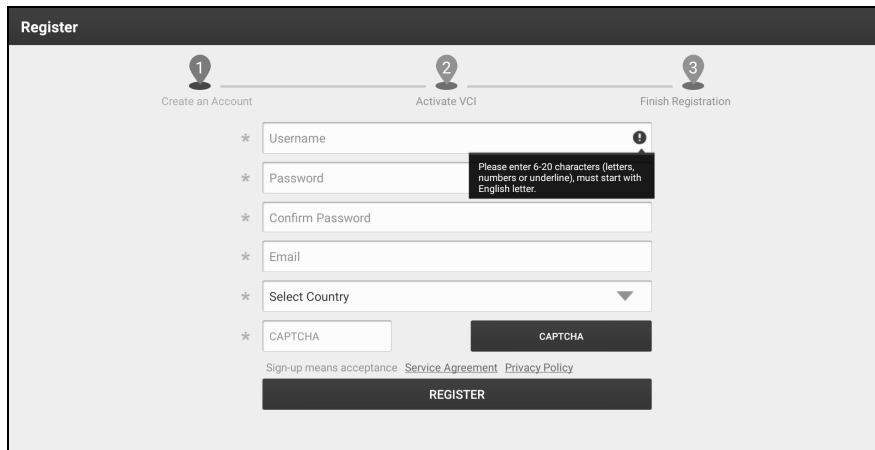

2. Activate VCI: Input the Product Serial Number and Activation Code, and tap **Activate** to go to the next step.

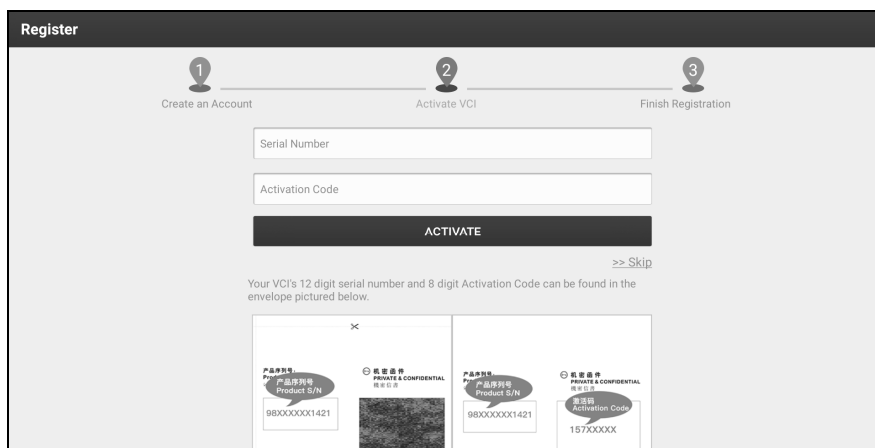

Input the Product Serial Number and Activation Code can be found in the supplied Password Envelope.

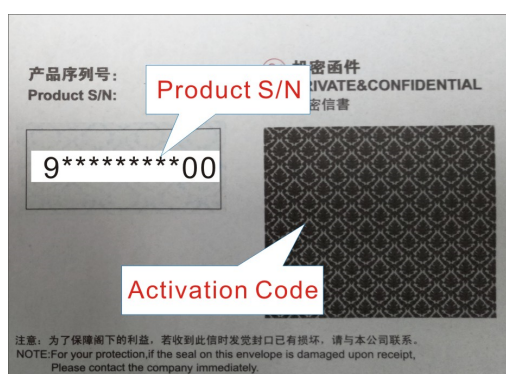

**Note:** To exit and activate it later, tap **Skip**. In this case, you can activate the VCI by tapping **User Info** -> **Activate VCI**.

After the registration is successfully complete, the wireless communication between the tablet and the VCI device is automatically established and user has no need to configure it again.

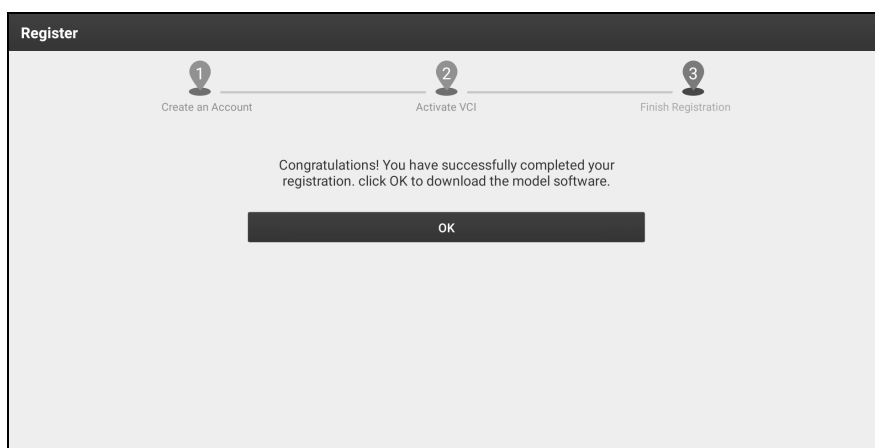

3. **Finish Registration:** Tap **OK** to navigate to the download page and download the diagnostic software.

On the download page, tap **Update** to start downloading. To pause downloading, tap **Stop**. Once download is complete, the system will install the software package automatically.

**Note:** When downloading the diagnostic software or checking for updates, make sure the tablet has a strong signal. It may take a long time to finish it, please be patient to wait.

B. **If you have registered to be a member,** input your name and password, and then tap the **Login** button to enter the main menu screen directly.

**Note:** The tablet has an auto-save function. Once the username and password are correctly entered, the system will automatically store it. After initial setup, it is no longer necessary to input the account information manually to log in.

C. **If you have created a sub-account or bound an existing account to the tool,** tap **Technician login** to login. For more

details on sub-accounts, refer to Chapter 10.11.8.

D. If you forgot the password, tap **Retrieve password** and then follow on-screen instructions to set a new password.

### 3.2 Home Screen

It mainly includes the following items:

Name	Description
<b>Intelligent Diagnose</b>	<ul style="list-style-type: none"> <li>Obtain vehicle data from the cloud server to perform quick test via reading VIN, to avoid various defects resulting from step-by-step menu selection.</li> <li>Check the historical repair records online.</li> </ul>
<b>Local Diagnose</b>	Diagnose a vehicle manually.
<b>EV</b>	<p>To diagnose the electronic control systems, detect battery pack and perform some service functions of new-energy vehicles.</p> <p> Note: This function needs to work with New Energy Vehicle Diagnosis Add-on Kit (optional), which can be purchased from the authorized dealer.</p>
<b>Remote Diagnose</b>	There are two remote diagnostics platforms available: SmartLink Super remote diagnostics solution and X431 Remote Diagnostics.
<b>Special Function</b>	It offers coding, reset, relearn and more service functions, to help vehicles get back to functional status after repair or replacement.
<b>Toolbox</b>	Additional add-on tools include TPMS, ADAS, Oscilloscope, Sensor simulator, BST360 Battery Tester, Immobilizer programmer, Videoscope, Current clamp, Multimeter, Insulation Tester, Key programmer and more.
<b>Software Update</b>	Update vehicle diagnostic software and APK.
<b>Feedback</b>	Feedback the recent 20 diagnostic logs to us for issue analysis.
<b>X-431 Diagnostic Widget</b>	Includes vehicle coverage, CANBUS pin detection, CANScope, and Fix connector firmware/system etc.
<b>Mall</b>	An online diagnostic software store. This module enables you to subscribe some extra software or service functions that are not integrated in the tool online.
<b>Info Center</b>	Include user manual, FAQ, training videos and repair information etc.
<b>Diagnostic History</b>	Provide a quick access to the tested vehicles and users can resume from the last operation, without starting from scratch.
<b>User Info</b>	Manage VCI, diagnostic reports & records, change password, order and logout / login etc.
<b>Settings</b>	Make some system settings of diagnostic application.



## 4 Connections

### 4.1 Preparation

- The ignition is turned on.
- The vehicle battery voltage range is 9-14V or 18-30V.
- The throttle is in closed position.
- Find DLC location:

For passenger cars, the DLC (Data Link Connector) is usually located 12 inches from the center of the instrument panel, under or around the driver's side for most vehicles. For some vehicles with special designs, the DLC location may vary. Refer to the following figure for location.

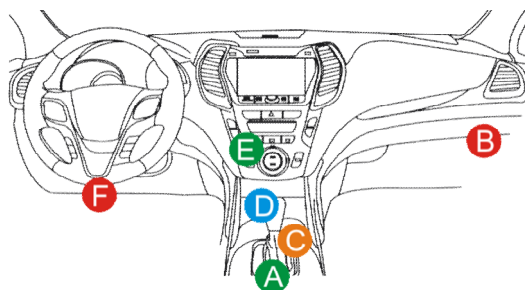

A. Opel, Volkswagen, Audi

B. Honda

C. Volkswagen

D. Opel, Volkswagen, Citroen

E. Changan

F. Hyundai, Daewoo, Kia, Honda, Toyota, Nissan, Mitsubishi, Renault, Opel, BMW, Mercedes-Benz, Mazda, Volkswagen, Audi, GM, Chrysler, Peugeot, Regal, Beijing Jeep, Citroen and other most popular models

If the DLC cannot be found, refer to the vehicle's service manual for the location.

For commercial vehicles, the DLC is always located in driver's cab.

### 4.2 Vehicle Connection

The method used to connect the VCI device to a vehicle's DLC depends on the vehicle's configuration as follows:

For OBD II vehicles, use the included diagnostic cable (DB15F to HD15F data cable and HD15M to OBD16 adaptor) to connect the VCI to the vehicle's DLC port.

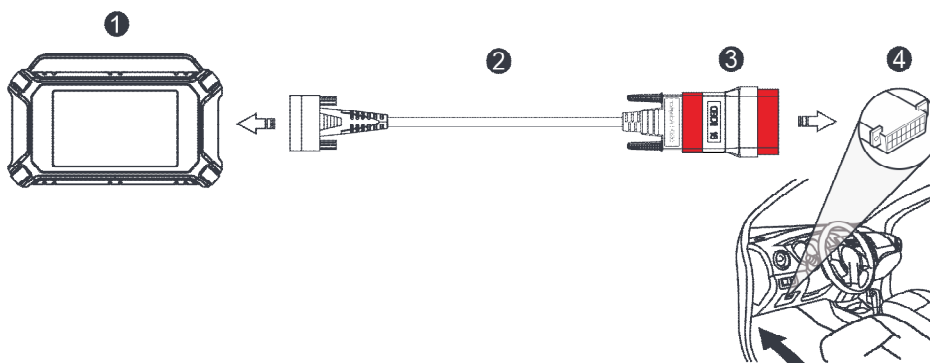

1. VCI

2. DB15F to HD15F data cable

3. HD15M to OBD16 adaptor

#### 4. Vehicle's DLC port

For non-OBDII vehicles, refer to the above figure to make connection.

1. Select the appropriate adaptor according to the vehicle's DLC port type (4).
2. Loosen the captive screws of the DB15F to HD15F data cable (2) and disconnect the HD15M to OBD16 adaptor (3) from the data cable.
3. Connect the data cable (2) with the target adaptor (sold separately) on the above figure and tighten the screws.  
Other steps shall also apply.

If you choose to perform vehicle diagnosis via data cable, connect one end of the data cable into the VCI, and the other end into the data I/O port of the tablet.

### 4.3 Communication Setup

There are two kinds of ways available for the tablet to communicate with the VCI device: wireless and wired (USB).

After the user registration is successfully finished, the wireless communication between the tablet and the VCI device is automatically established and user has no need to configure it again.

The USB connection is a simple & quick way to establish communication between the tablet and the VCI. After properly connecting the data cable from the tablet to the VCI, the VCI navigation button at the bottom of the screen will be enabled indicating the USB connection is successful.

 Note: The USB connection provides the most stable and fastest communication. When all communication methods are applied at the same time, the tablet will use the wired communication as the default priority.

## 5 Diagnosis

### 5.1 Intelligent Diagnose

Through simple wireless communication between the tablet and VCI, you can easily get the VIN (Vehicle Identification Number) information of the currently identified vehicle. Once the VIN is successfully identified, the system will retrieve it from the remote server and then guide you to vehicle information page without performing step-by-step manual menu selection.

The vehicle information page lists all historical diagnostic records of the vehicle, which lets the technician have a total command of the vehicle faults. In addition, a quick dial to Local Diagnose and diagnostic function are also available on this page for reducing the roundabout time and increasing productivity.

#### Notes:

- Before using this function, please make sure the VCI is properly connected to the vehicle's DLC port. For detailed connection, see Chapter 4.2.
- A stable network connection is required for this function.

Follow the steps below to proceed.

1. Tap **Intelligent Diagnose**, the following screen will appear.

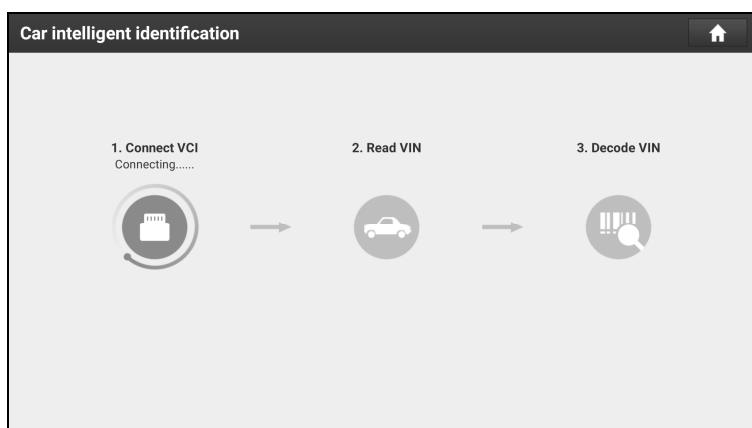

2. After pairing is complete, the tablet starts reading the vehicle VIN.

- A. If the VIN can be found from the remote server database, the following screen will appear:

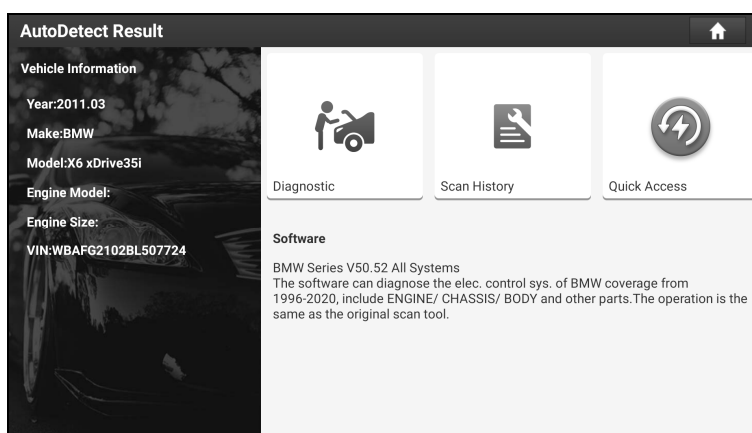

- Tap **Diagnostic** to start a new diagnostic session.
- To perform other functions, tap **Quick access** to directly go to the diagnostic function selection screen. Choose the desired one to start a new diagnostic session.
- Tap **Scan History** to view its historical repair record. If there are records available, it will be listed on the screen in

## LAUNCH

sequence of date. If no records exist, the screen will show *No Record*.

- Tap **View record** to view the details of the current diagnostic report.
- To perform other functions, tap **Quick access** to directly go to the diagnostic function selection screen. Choose the desired one to start a new diagnostic session.



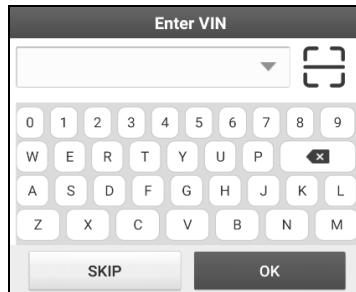

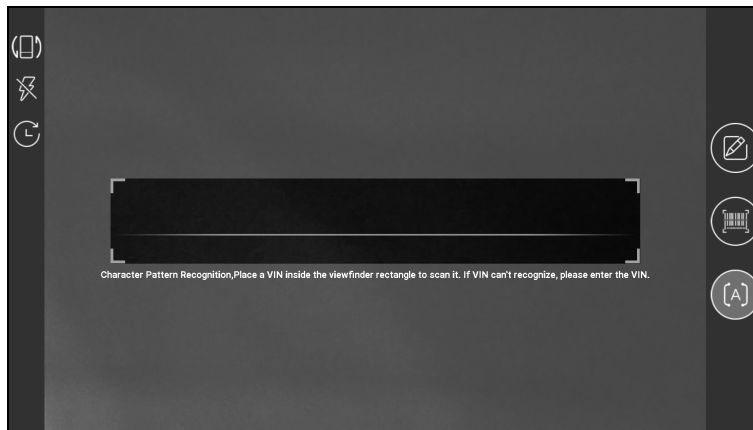

B. If the tablet failed to access the VIN information, the following screen will appear:



- Tap the input field to directly, tap **OK**. If the VIN exists on the remote server, the system will enter the diagnostic function selection screen.
- Tap  to launch the VIN recognition module.



Place the VIN inside the viewfinder rectangle to scan it. The most recognizable location for this number is in the top left corner on the vehicle's dashboard. Other locations include the driver's door or post, and the firewall under the hood.

- Tap  to switch the display mode of the screen.
- Tap  to turn the camera flash on.
- Tap  to choose it from the record list if the VIN of the vehicle has been scanned before.
- Tap  to input the VIN manually if the tablet has failed to identify the VIN of the vehicle.
- Tap  to scan the VIN barcode. If the VIN barcode cannot be recognized, please manually input the VIN.
- Tap  to scan the VIN character. If the VIN character cannot be recognized, please manually input the VIN.

 **Note:** In general, vehicle identification numbers are standardized - all contain 17 characters. VIN characters may be capital letters A through Z and numbers 1 through 0; however, the letters I, O and Q are never used in order to avoid mistakes of misreading. No signs or spaces are allowed in the VIN.

After scanning, the screen automatically displays the result.

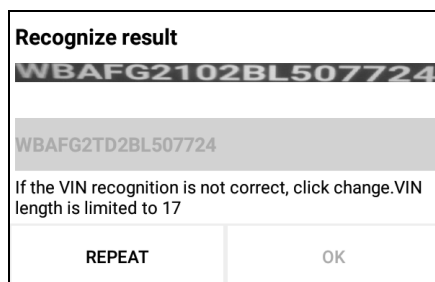

- If the VIN scanned is incorrect, tap the result field to modify it and then tap **OK**.
- To scan it again, tap **REPEAT**.

If the VIN exists on the remote server, the system will enter the diagnostic function selection screen.

## 5.2 Local Diagnose

This function allows you to diagnose electronic control systems of single vehicle models by manually executing the menu-driven command.

Tap **Local Diagnose** to enter the vehicle selection page.

2 approaches are provided for you to access the vehicle diagnostic software. Choose any one of the following ways:

1. Operations of VINSCAN Service are same as Intelligent Diagnose. Refer to Chapter 5.1 for details.
2. Tap a corresponding diagnostic software logo, and then follow the on-screen instruction to access the diagnostic software.

Take Demo (Version 15.54) as an example to demonstrate how to diagnose a vehicle.

- 1). Select diagnostic software version: Tap the **DEMO** to go to Step 2.

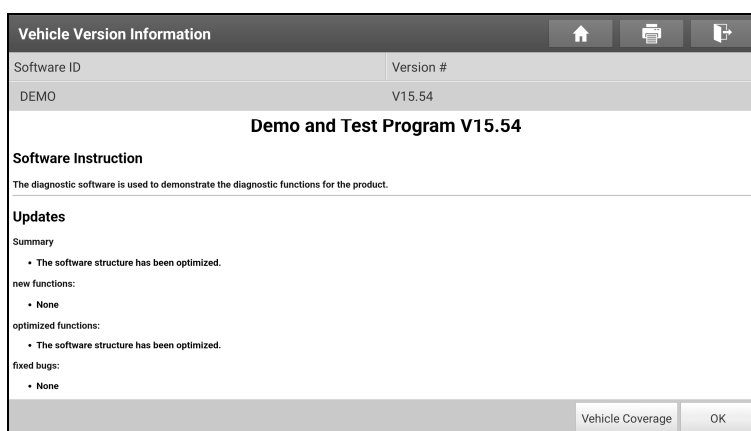



### On-screen Buttons:

**Vehicle Coverage:** Tap to view the vehicle models that the current diagnostic software covers.

**OK:** Tap it to go to next step.

The diagnostics toolbar contains a number of buttons that enable various procedures. It is displayed at the top of the vehicle diagnostic screen throughout the whole diagnostic session. Refer to the table below for a brief description of the functions of the diagnostics toolbar buttons:

 **Home:** Return to the home screen.

 **Print:** Tap to print the selected screenshots out via external printer. The printer needs to be configured separately. For details on printer setting, refer to Chapter 11.3.

 **Exit:** Exit the diagnostic application.

- 2). Select vehicle model. Here we take **TOYOTA** for example to demonstrate how to diagnose a vehicle.

- 3). Select the desired test item to proceed.

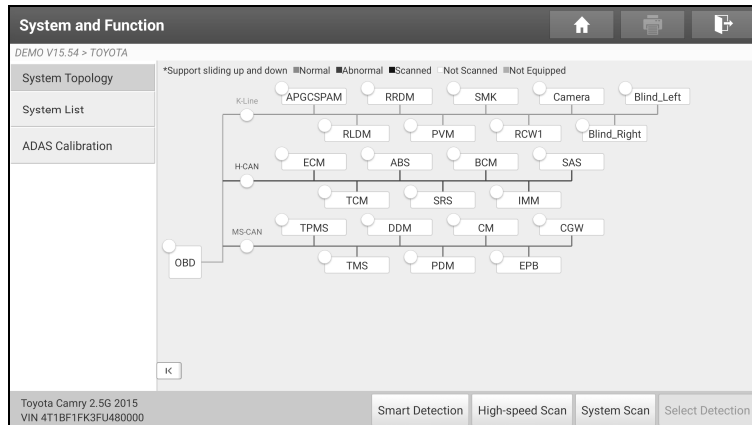

**System Topology:** Displays all available vehicle systems in form of topology structure.

**System List:** Displays all available vehicle systems in form of list.

**ADAS Calibration:** Performs ADAS calibration operations. It is extracted from the system list as a functional module and provides a quick access to ADAS system.

- While in System Topology mode, different highlight bars indicate different detection status.

**On-screen Buttons:**

**Smart Detection:** Tap to quickly access all the electronic control units of the vehicle and generate a detailed report about vehicle health. The tested systems malfunctioning are displayed in red with a number indicator displaying DTC quantity and the systems with functioning properly are displayed in green.

 **Note:** Diagnostic Trouble Codes or Fault Codes can be used to identify which engine systems or components that are malfunctioning. Never replace a part based only on the DTC definition. Retrieving and using DTCs for troubleshooting vehicle operation is only one part of an overall diagnostic strategy. Follow testing procedures (in vehicle’s service manual), instructions and flowcharts to confirm the locations of the problem.

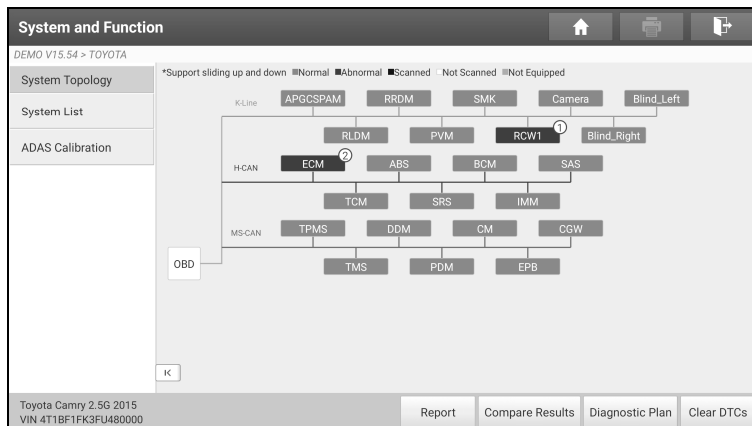

- **Report:** Tap to save the current data in text format. All reports are saved in **User Info -> My Report -> Health Reports**.

 **Notes:**

1. Diagnostic report is classified into two categories: Pre-Repair report and Post-Repair report. To facilitate the comparison of the pre-repair and post-repair reports and get accurate test result, please make sure you saved the right type of the diagnostic report.
2. By default, the workshop information is blank. You can configure and revise it from Settings -> Shop Information. After you configured the information, it will be automatically generated every time the diagnostic report is saved. All vehicle and workshop information will be appended as a tag on the diagnostic report, which allows you to easily retrieve the desired report while performing Filter function of Diagnostic Report.

- **Compare Results:** Tap to select the pre-repair report to compare. By comparison of the pre- and post- repair reports, you can easily identify which DTCs are cleared and which remain unfixed.

Compare Results		
DTC	Post	Pre
Engine		
P2118 Throttle Actuator 'A' Control Motor Range/Performance	Cleared	Found
P0504 Brake Switch A/B Correlation	Cleared	Found
Radar Cruise 1		
C1521 CAN bus:Signal Failure	Cleared	Found

 Note: Before performing this function, please make sure that: 1) You have saved a pre-repair report of the currently tested vehicle; and 2) You have already made some repairs and service and cleared the DTCs after the pre-repair reported is generated. Otherwise, no differences exist between the pre- and post- repair reports.

- **Diagnostic Plan:** Figures out the diagnostic plan and repair solutions for the detected DTCs.
- **Clear DTCs:** Tap to clear the existing diagnostic trouble codes.

 Note: Clearing DTCs does not fix the problem(s) that caused the code(s) to be set. If proper repairs to correct the problem that caused the code(s) to be set are not made, the code(s) will appear again and the check engine light will illuminate as soon as the problem that cause the DTC to set manifests itself.

**High-speed Scan:** Tap to simultaneously scan all vehicle systems and generate a detailed report about vehicle health. This function runs faster than smart detection.

**System Scan:** Tap to scan which systems are installed on the vehicle.

**Select Detection:** Select certain system manually to start scanning.

- While in System List mode, the following screen will appear.

System and Function		
DEMO V15.54 - TOYOTA		
System Topology	<input type="checkbox"/> OBD	
System List	<input type="checkbox"/> Engine	Not Scanned <input type="button" value="Enter"/>
ADAS Calibration	<input type="checkbox"/> Transmission	Not Scanned <input type="button" value="Enter"/>
	<input type="checkbox"/> ABS/VSC/TRAC/EPB	Not Scanned <input type="button" value="Enter"/>
	<input type="checkbox"/> SRS Airbag	Not Scanned <input type="button" value="Enter"/>
	<input type="checkbox"/> Main Body	Not Scanned <input type="button" value="Enter"/>
	<input type="checkbox"/> Theft Deterrent	Not Scanned <input type="button" value="Enter"/>
	<input type="checkbox"/> Steering Angle Sensor	Not Scanned <input type="button" value="Enter"/>
	<input type="checkbox"/> Tire Pressure Monitor	Not Scanned <input type="button" value="Enter"/>
Toyota Camry 2.5G 2015 VIN 4T1BF1FK3FU480000		
<input type="button" value="Smart Detection"/> <input type="button" value="High-speed Scan"/> <input type="button" value="System Scan"/> <input type="button" value="Select Detection"/>		

- **Enter:** Select certain system, and tap this button to enter the diagnostic function selection screen.

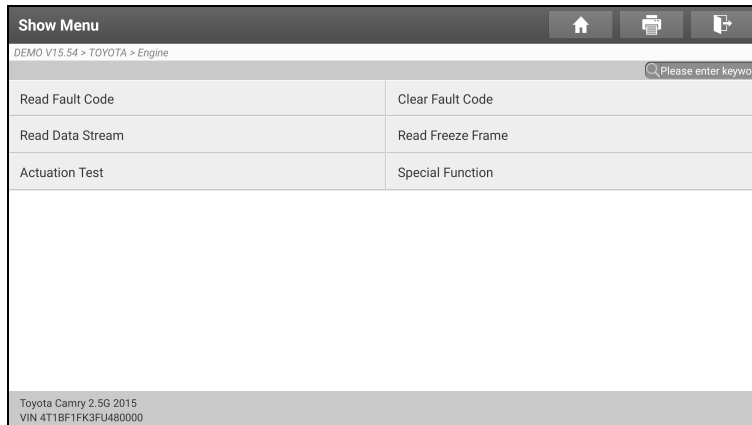

In general, the diagnostic functions vary with different vehicle models. It mainly includes the following options:

**A. Read Fault Code**

This function displays the detailed information of DTC records retrieved from the vehicle’s control system.

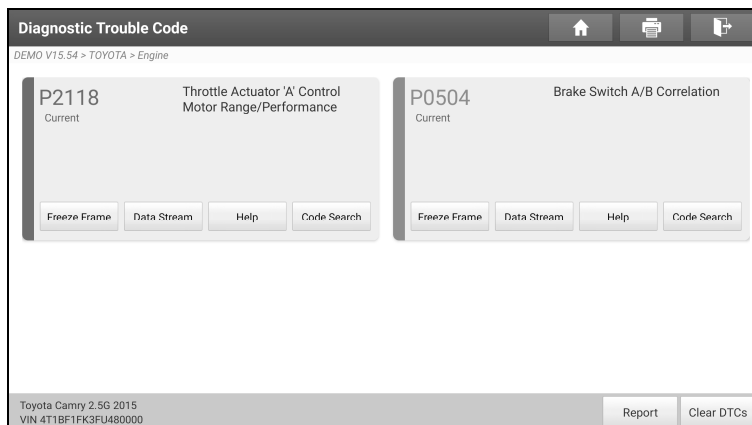

**On-screen Buttons:**

**Freeze Frame:** Tap it to view the snapshot of critical parameter values at the time the DTC is set.

**Help:** Tap to view the help information.

**Code Search:** Tap it to search for more information about the current DTC online.

**Report:** To save the current data in text format. All reports are saved in **User Info -> My Report -> Health Reports**.

**Clear DTCs:** Tap to clear the existing diagnostic trouble codes.

**B. Clear Fault Code**

This option can erase the codes from the vehicle. Before the operation, please make sure the vehicle’s ignition key is in the ON position with the engine off.

 **Note:** After clearing, you should retrieve trouble codes once more or turn ignition on and retrieve codes again. If there are still some trouble codes in the system, please troubleshoot the code using a factory diagnosis guide, then clear the code and recheck.

**C. Read Data Stream**

This option retrieves and displays live data and parameters from the vehicle’s ECU.

 **Caution:** If you must drive the vehicle in order to perform a troubleshooting procedure, ALWAYS have a second person help you. Trying to drive and operate the diagnostic tool at the same time is dangerous, and could cause a serious traffic accident.

 **Note:** The real time (Live Data) vehicle operating information (values/status) that the on-board computer supplies to the tool for each sensor, actuator, switch, etc. is called Parameter Identification Data (PID).

Tap **Read Data Stream**, the following screen will appear:



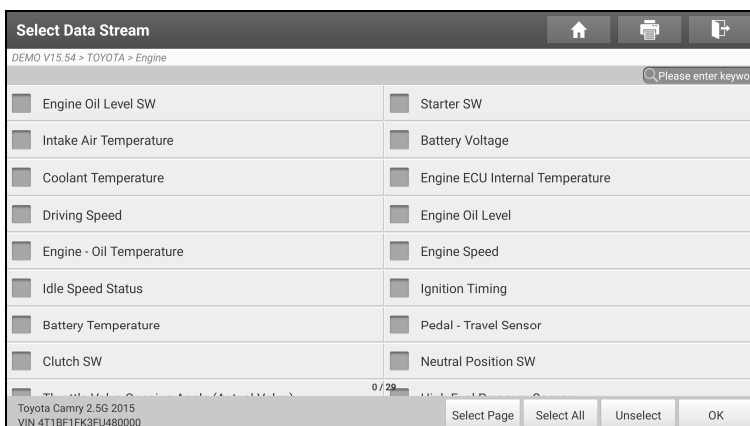

After selecting the desired items, tap **OK** to enter the data stream reading page.

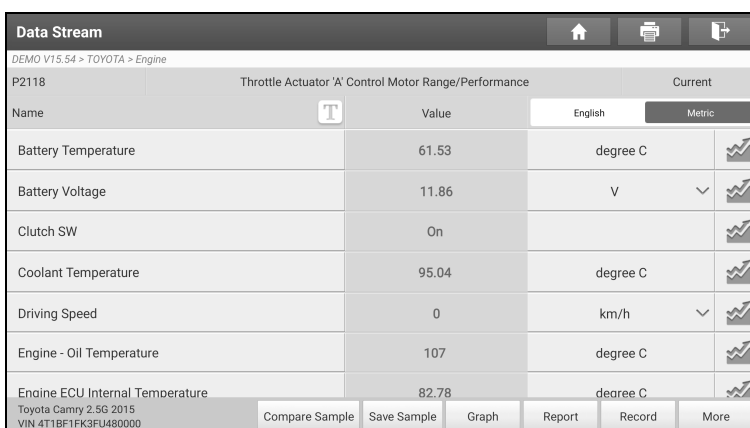

**Notes:**

1. Tap to set the display style. indicates sticky top. If it is tapped, it will change into . On the data stream display screen, the data stream item with will be shown on the top of the selected data stream list. To remove it from the top of the list, just tap it again. B indicates this item will be displayed in **Bold**. A indicates this item will be displayed in Red.
2. Tap **English** or **Metric** to switch the measurement unit.
3. If the value of the data stream item is out of the range of the standard (reference) value, the whole line will display in red. If it complies with the reference value, it displays in blue (normal mode).

There are 3 types of display modes available for data viewing, allowing you to view various types of parameters in the most suitable way.

- Value – this is the default mode which displays the parameters in texts and shows in list format.
- Graph – displays the parameters in waveform graphs.
- Combine – this option is mostly used in graph merge status for data comparison. In this case, different items are marked in different colors.

**On-screen Buttons:**

: Tap it to view the live waveform.

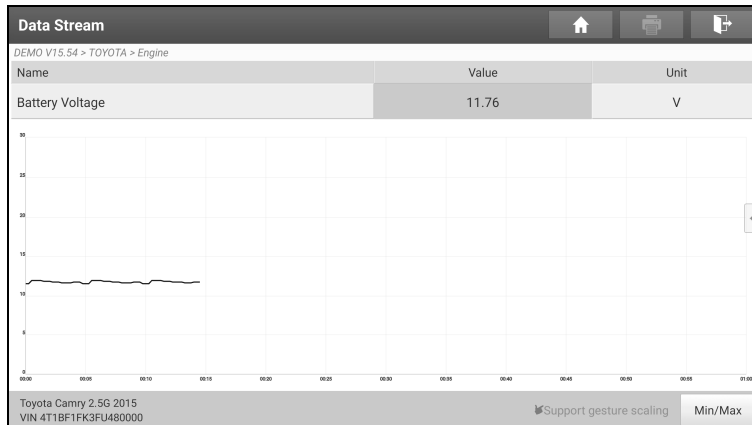

**Graph:** Tap it to view the waveform of the selected data streams. Tap on the edge of the screen to customize the target data streams for displaying.

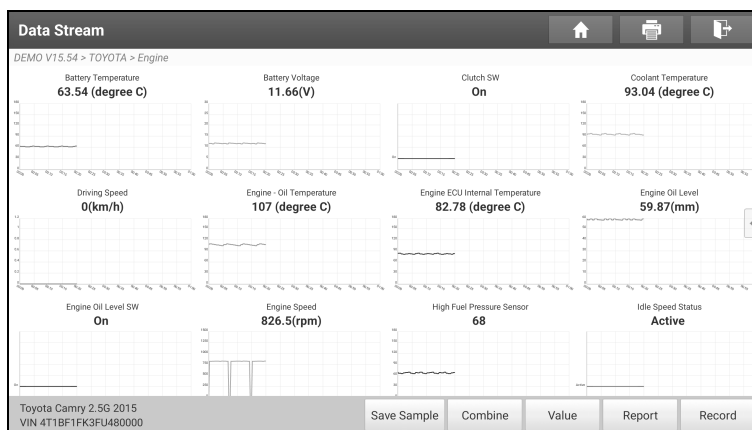

**Compare Sample:** Tap it to select the sample data stream file, the values you customized and saved in process of data stream sampling will be imported into the **Standard Range** column for your comparison.

**Note:** Before executing this function, you have to sample the values of data stream items and save it as a sample data stream file.

**Report:** To save the current data in text format. All reports are saved in **User Info -> My Report -> Health Reports**.

**Record:** Tap to start recording diagnostic data. Recorded live data can serve as valuable information to help you in troubleshooting of vehicle problems. All recorded files are stored in **User Info -> My Report -> Recorded Data**.

**Help:** Tap to view the help information.

**Save Sample:** This item enables you to customize the standard range of live data stream items and save it as sample file. Each time you run the data stream items, you can call out the corresponding sample data to overwrite the current standard range.

Tap it to start recording the sample data ( **Note:** Only data stream items with units will be recorded). Once recording is complete, tap to stop it and navigate to the data modification screen.

Confirm Sample DS			
DEMO V15.54 > TOYOTA > Engine			
Name	Min Value	Max Value	Unit
Battery Temperature	61.53	63.54	degree C
Battery Voltage	11.66	11.86	V
Coolant Temperature	93.04	96.04	degree C
Driving Speed	0.0	0.0	km/h
Engine - Oil Temperature	104.0	107.0	degree C
Engine ECU Internal Temperature	80.98	83.78	degree C
Engine Oil Level	58.67	59.87	mm
Engine Speed	822.55	825.54	rpm
Toyota Camry 2.5G 2015 VIN 4TTB1FK3FU480000			Save

Tap the value to change it. After modifying all desired items, tap **Save** to save it. All data stream files are stored in **Diagnostic Widget -> Sample**.

**D. Read Freeze Frame**

This option takes the snapshot of the operating conditions when a vehicle fault occurs.

**E. Actuation Test**

This option is used to access vehicle-specific subsystem and component tests. Available test vary by vehicle manufacturer, year, and model.

During the actuation test, the tablet outputs commands to the ECU in order to drive the actuators, and then determines the integrity of the system or parts by reading the ECU data, or by monitoring the operation of the actuators, such as switching a injector between two operating states.

**F. Special Functions**

This option offers coding, reset, relearn and more service functions, to help vehicles get back to functional status after repair or replacement. Available tests vary by vehicle manufacturer, year, and model.

**5.3 Remote Diagnose**

**5.3.1 SmartLink super remote diagnostics**

SmartLink is a newly developed powerful service system dedicated to remote vehicle diagnosis and service. In the SmartLink ecology system, if a technician (SmartLink C) does not have time to puzzle through a tough vehicle problem, he can seek a trusted second opinion or additional expertise on various vehicle issues from remote master technicians or repair shops (SmartLink B). SmartLink B enables the shop owner to greatly increase customer’s retention and boost shop revenue by providing the professional technical assistance service.

It mainly consists of the following parts:

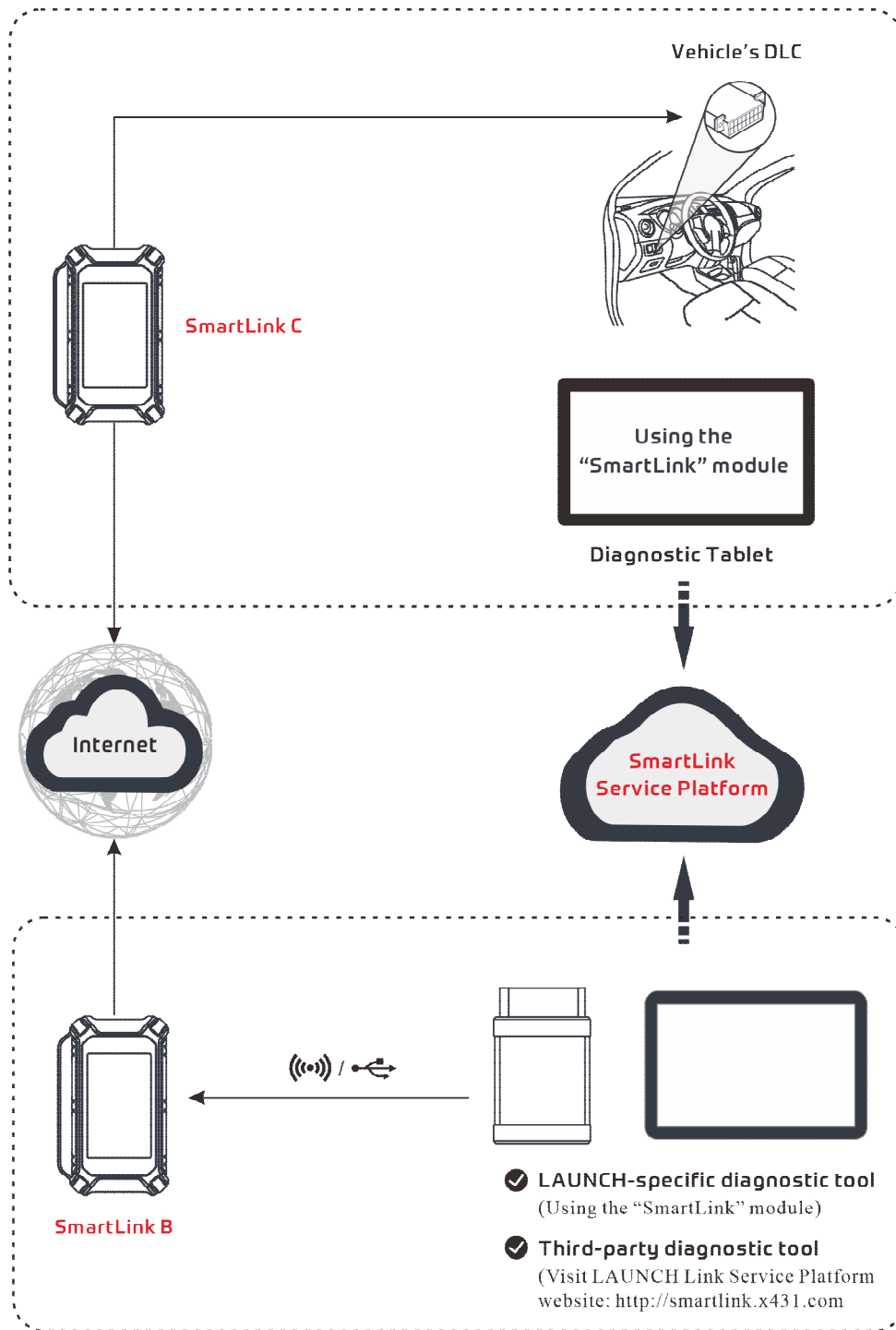

- **SmartLink Service Platform** – It can be accessed from the **SmartLink** module of the diagnostic tablet. There are two modules available on the link service platform: **Common user** (for SmartLink C) and **Service provider** (for SmartLink B).
- **SmartLink C (Customer) - SmartLink Service Subscriber.** In the SmartLink system, the SmartLink C needs to perform the following operations.
  - 1). Launch Service Link Platform: Binds SmartLink C dongles and submits remote repair orders.
  - 2). SmartLink C Dongle: Connects to the vehicle's DLC port for collecting the vehicle data and sends it to the remote SmartLink B.

It supports remote diagnostic services for vehicles that meet CAN / CAN FD / J2534 vehicle diagnostic standards.
- **SmartLink B (Business) - SmartLink Service Provider.** In the SmartLink system, the SmartLink B needs to

perform the following operations.

- 1). Launch Service Link Platform: Binds SmartLink B dongle and accepts orders from SmartLink C.
  - If the SmartLink B dongle works with the LAUNCH-specific diagnostic tool equipped with SmartLink module, tap **SmartLink** to add the SmartLink B device and accepts orders on the diagnostic tool.
  - If the SmartLink B dongle works with the third-party diagnostic tool, open the browser and visit SmartLink Service Platform website <http://smartlink.x431.com> (web client) to add the SmartLink B device and accepts orders in the browser.
- 2). SmartLink B Dongle: After accepting the orders, it can work with the compatible diagnostic tool to perform diagnosis of the vehicle connected to the SmartLink C dongle.

For more detailed operations, refer to the User Manual integrated in the SmartLink Platform.

### 5.3.2 X431 remote diagnostics

This option aims to help repair shops or technicians launch instant messaging and remote diagnosis, making the repair job getting fixed faster.

Tap **Remote Diagnose** -> **X431 Remote Diagnosis** to enter the following screen.

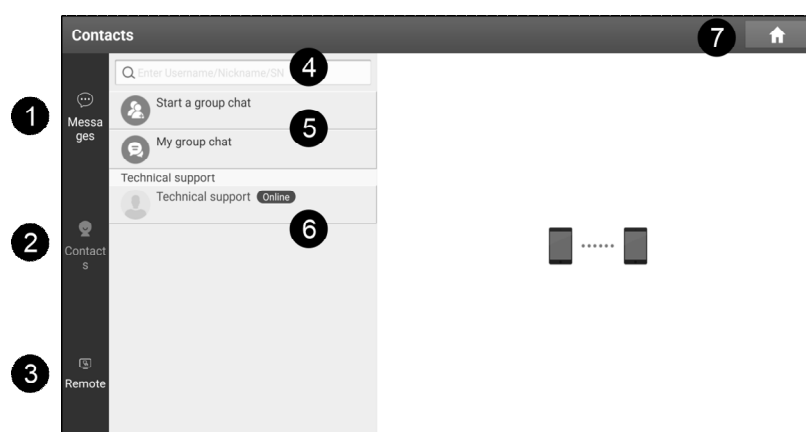

1	Messages tab	Once an incoming message reaches, a red dot will appear on the upper right corner of the tab.
2	Contacts tab	Tap to enter the friend list.
3	Remote	Tap to slide the switch to ON, the tool keeps online and becomes accessible on the web client. In this case, inform the technician of your product S/N, and he/she will control your device remotely.
4	Search bar	Directly input the registered username of the tool to start searching, and then tap the desired one to add it into your friend list.
5	Group chat operation	Used to start a group chat and manage group chat.
6	Contacts list	Displays a list of friends. The technical support is displayed by default if no friends list is created.
7	Home button	Tap it to navigate to the home screen.

#### 1. Adding friends

Tap **Contacts** to enter the contact page. By default it appears blank.

In the search bar, input the partner's username and tap **Search** button next to the search bar to starts searching from Launch's business database.

The partner must be the users who have registered their Launch-specific diagnostic tools. They may be the following:

## LAUNCH

- Workshop
- Technician
- golo users

Once the result matches the keyword, the following screen will appear:

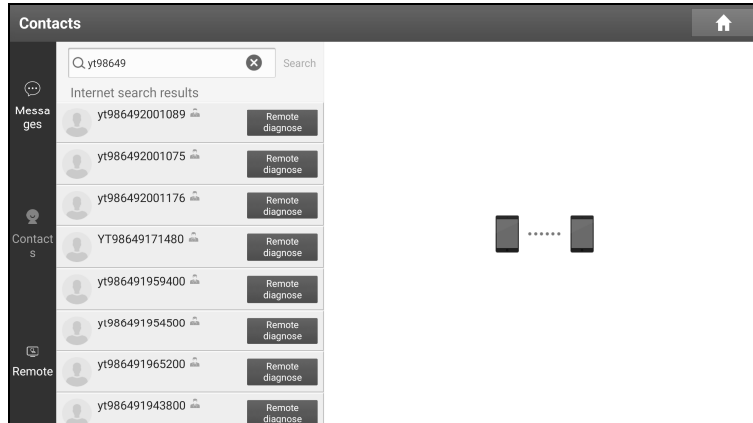

Tap **Remote Diagnose** to launch remote diagnostics directly or follow the steps below to add the partner into the Contacts list.

Tap the desired name from the list, the following screen will appear:

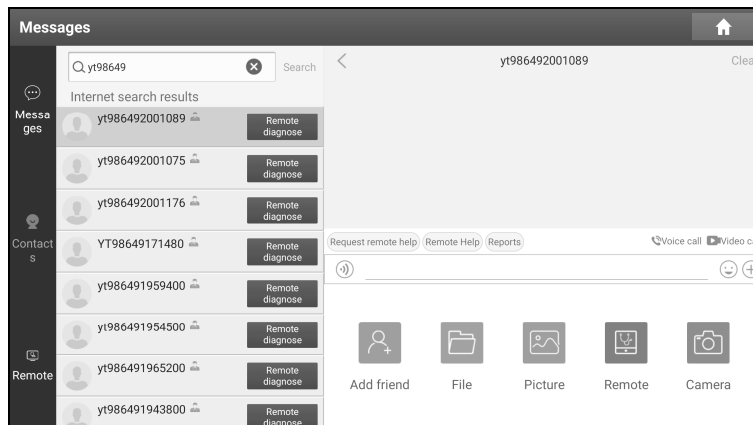

Tap **Add friend** to send your request.

Once the partner receives the request, a beep will sound. Tap the **Message** tab:

- Once the partner agreed your request, he/she will automatically be listed in the **Contacts** tab.
- If a technician sent you a friend request, tap **Agree** and his/her name will appear in the friend (**Contacts**) list. Or tap **Ignore** to ignore this request.

## 2. Start instant messaging

The I/M (Instant Messaging) function is open to all users who had the diagnostic tool equipped with this module.

After adding your friends, tap the desired one's photo to enter the following screen:

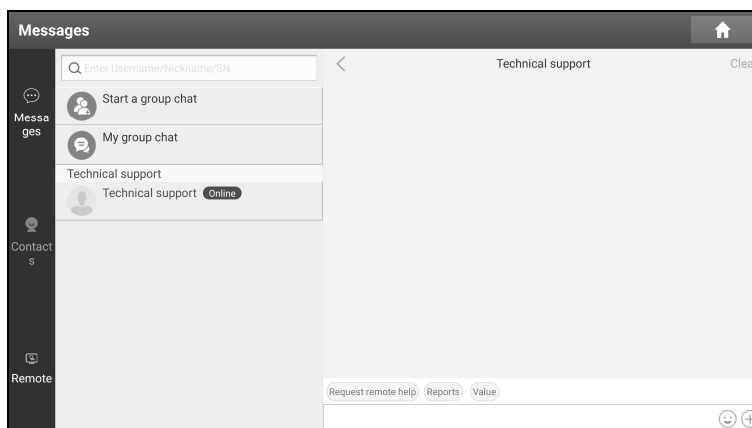

Tap the input field and use the on-screen keyboard to enter the text message, and then tap **Send** to send it.

Tap 😊 to send the emoji.

Tap + to call out the following function options:

**File:** Choose diagnostic reports or local files to send.

**Picture:** Choose screenshots or pictures to send.

**Remote Diagnose:** To start a remote diagnostic session.

**Camera:** Open camera to take pictures.

Tap **Clear** to delete all the partner’s dialog logs.

### 3. Launch Remote Diagnosis (Scanner-To-Scanner)

The tool is allowed to initiate remote diagnosis with other diagnostic tools, which are equipped with this module.

On the function option selection screen, tap **Remote Diagnostic**, the following pull-down menu will appear:

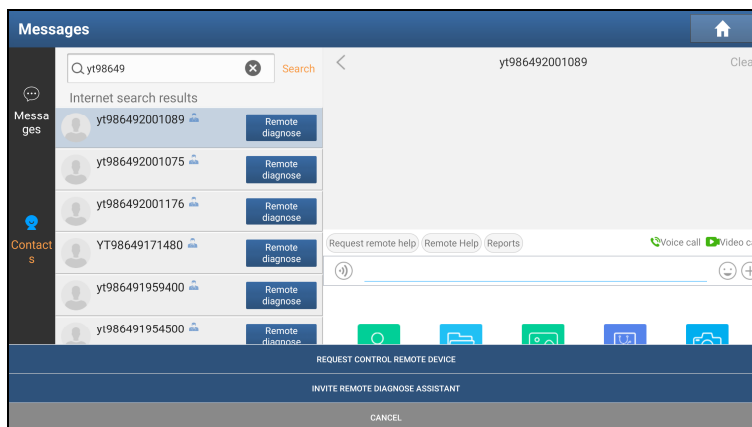

These options are defined as follows:

Actions	Results
Request control remote device	Request to control the partner’s device remotely to help him diagnose the vehicle.  Note: Once vehicle diagnosis is complete, a report will be created. Input your comments on this report, and then tap <b>Send Report</b> to send it to the partner.

	<pre> graph TD     A[Tap "Request control remote device"] --&gt; B[Wait for partner's confirmation]     B --&gt; C[Start connecting after request confirmed]     C --&gt; D[Start Diagnosis]     D --&gt; E[Generate diagnostic report]             </pre>
<p>Invite remote diagnostic assistant</p>	<p>Use this option to invite a technician to perform a remote control on your tool.</p> <p> Note: Once you received the report from the partner, tap <b>View Report</b> to view details. All diagnostic reports are saved under <b>User Info -&gt; My Report -&gt; Remote Report</b>.</p> <pre> graph TD     A[Tap "Invite remote diagnostic assistant"] --&gt; B[Choose the desired diagnostic software]     B --&gt; C[Wait for partner's confirmation]     C --&gt; D[Start connecting after request confirmed]     D --&gt; E[Start Diagnosis]     E --&gt; F[Generate diagnostic report]             </pre>
<p>Cancel</p>	<p>To cancel this operation.</p>

**4. Launch Remote Diagnosis (Scanner-To-PC)**

User also can ask for remote control from a PC client technician.



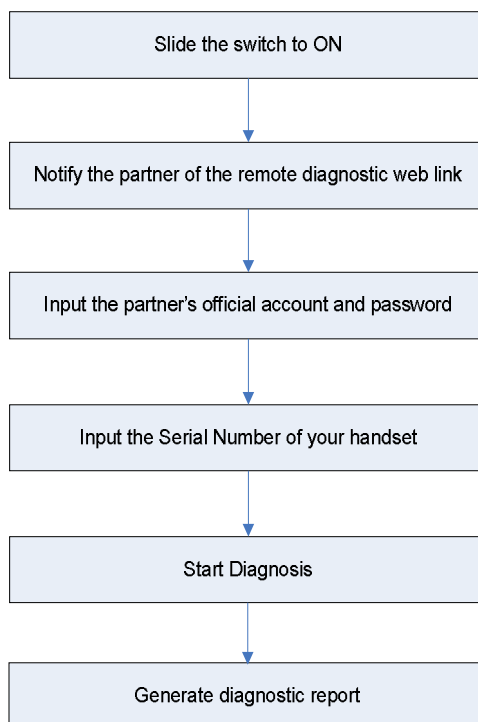

Tap **Remote**, the following screen will appear:

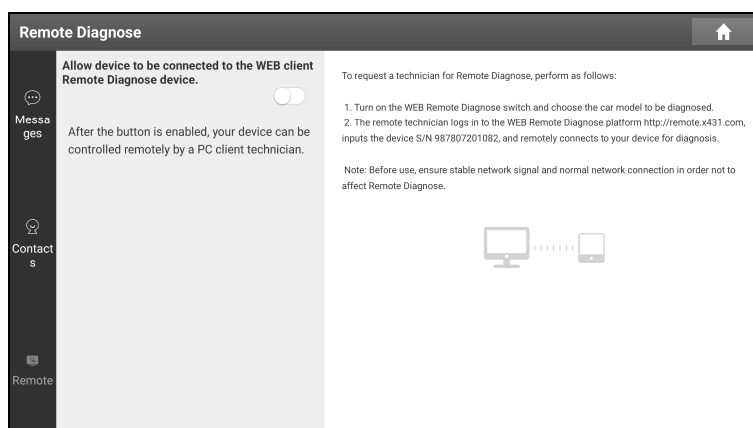

1. Slide the switch to ON so that the partner can find and connect to this device while using the PC.
2. Choose the car model to be diagnosed.
3. Notify the partner of the PC client website <http://remote.x431.com>. When the partner accesses the link, the PC displays as below:

 Note: Before processing remote diagnosis, please make sure the tool is properly connected to the vehicle.

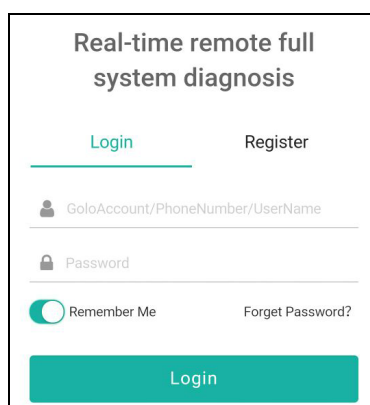

4. Tell the partner to input his own official technician account and password, and then tap **Login** to navigate to the following figure.

Remote diagnosis

Serial Number  
Locate the car to be diagnosed according to gold/AIT serial number

License Plate Number  
Locate the car to be diagnosed according to the car owner's license plate number

Phone Number  
Locate the car to be diagnosed according to the car owner's phone number

97229000223

Start remote diagnosis

Tips: Before starting remote diagnosis, confirm the car owner's car information and condition

5. Tell the partner to check the box **Serial number** and enter the Serial Number provided by you, and then tap **Start remote diagnosis** to control your device remotely.

In process of remote diagnosis, please note the following things:

- 1) You are not suggested to execute any actions.
- 2) The partner is not allowed to save any diagnostic reports or records on your tool.

The operations in remote diagnosis are same as those in local diagnose. Once the session is complete, a remote diagnostic report will be automatically generated.

## 5.4 EV (Electric Vehicle) Diagnose

This function only applies to the new energy vehicles. Vehicle diagnosis, battery pack detection and some service functions are available.

 Note: This function needs to work with New Energy Vehicle Diagnosis Add-on Kit (optional), which can be purchased from the authorized dealer.

### 5.4.1 Vehicle Diagnosis

This function is specially designed to manually diagnose electronic control systems of single new energy vehicle. Operations of this function are same as those in local diagnose. Refer to Chapter 5.2 for details.

### 5.4.2 Battery Pack Detection

This function can detect the battery pack of new energy vehicles. Two methods are provided for selecting the battery pack: via vehicle model and via battery brand.

Take BYD E5 as an example to demonstrate how to detect battery pack.

1. Tap **Battery Pack Detection**.
2. Tap **BYD -> E5**.
3. Choose the desired BMS model to enter the following screen.

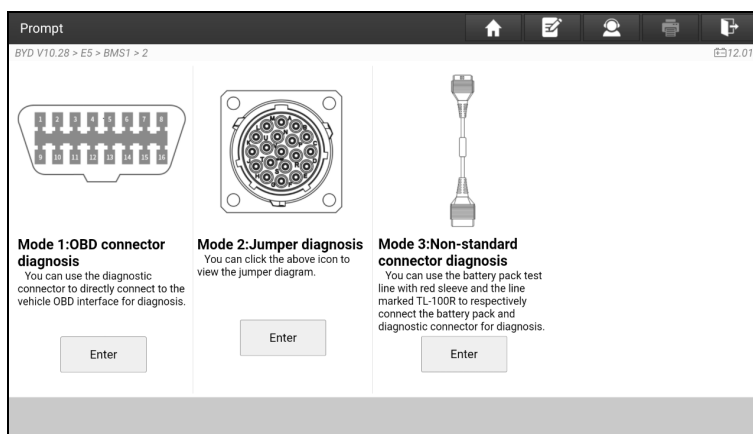

4. Select the preferred detection mode to start the detection until the system outputs the test result.

**Note:** The available detection mode varies with the vehicle model/battery brand. Generally the following modes are provided:

**Mode 1: Via OBD diagnostic interface**

Refer to Chapter 4.2 to make connection.

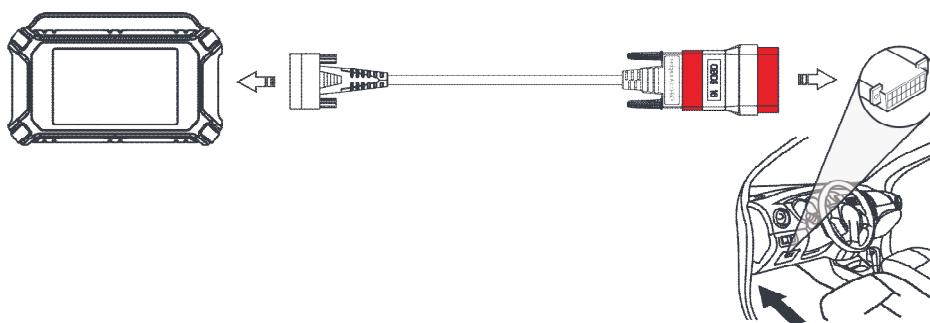

**Mode 2: Via Jumper**

1. Connect one end of the diagnostic cable to the DB15 diagnostic connector of the SmartLink C V3.0 device, and the other end to OBD-16 connector of the Jumper-8 line (sold separately).
2. Tap the icon shown on the screen to view the detailed connection prompts. Follow the onscreen instructions to connect the electronic control converter line (sold separately), diagnostic interface of battery pack and the Jumper-8 line (Each pin of Jumper-8 line has clear signal definition).
3. It is suggested that SmartLink C V3.0 device is connected to an external power source.

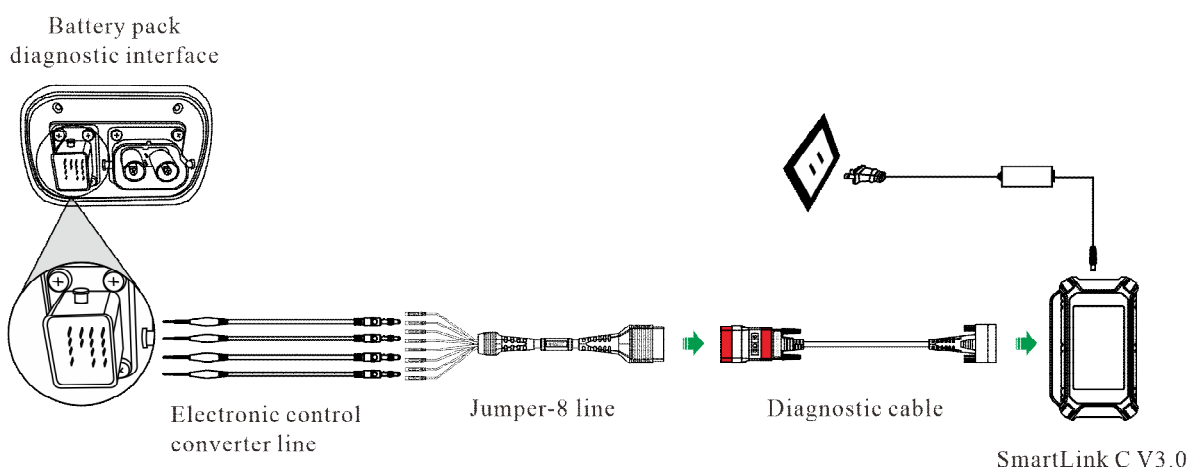

**Mode 3: Via Specific test adaptor**

1. Connect one end of the diagnostic cable to the DB15 diagnostic connector of the SmartLink C V3.0 device, and the other end to OBD-16 connector of the specific test adaptor (sold separately).

## LAUNCH

---

2. Plug the other end of the specific test adaptor to the diagnostic socket of the battery pack.
3. It is suggested that SmartLink C V3.0 device is connected to an external power source.

The specific test adaptor for battery pack varies with vehicle models/battery brands and the screen will prompt corresponding test adaptor model for current test.

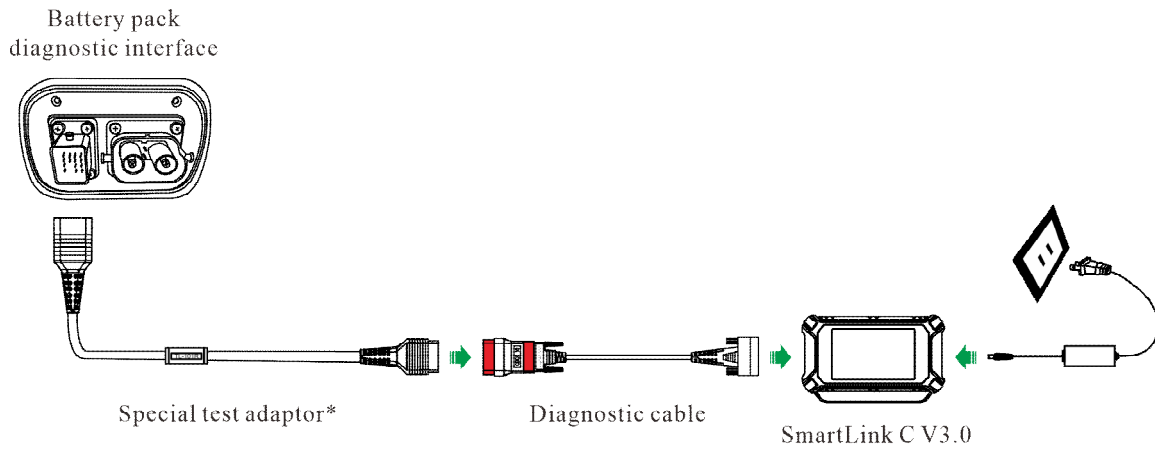

## 5.5 Diagnostic History

When a vehicle diagnosis is performed, the tablet records the detailed diagnostic information. The History function allows access to previously tested vehicle records. Testing can be resumed from the previous operation without starting from scratch.

Tap **Diagnostic History** on the home screen, all diagnostic records will be listed on the screen in date sequence.

## 5.6 Feedback

This function enables you to send the feedback of your diagnostic problems to us for further analysis and troubleshooting.

There are 3 options:

- 1). Feedback: To send a tested vehicle diagnostic feedback.
- 2). History: To view all diagnostic feedback records.
- 3). Offline list: To view all diagnostic logs that have failed to be submitted, which will be uploaded again to the remote server automatically once the tablet gets the stable network.

## 6 Service Function

It offers coding, reset, relearn and more service functions, to help vehicles get back to functional status after repair or replacement. Available tests vary by vehicle manufacturer, year, and model.

Due to continuing improvements, available service functions are subject to change without prior written notice. To enjoy more service functions, you are suggested to check for updates on a regular basis.

There are two methods to reset service lamp: Manual Reset or Auto Reset. Auto Reset follows the principle of sending command from the tool to vehicle's ECU to do resetting. While using Manual Reset, users just follow the on- screen instructions to select appropriate execution options, enter correct data or values, and perform necessary actions, the system will guide you through the complete performance for various service operations.

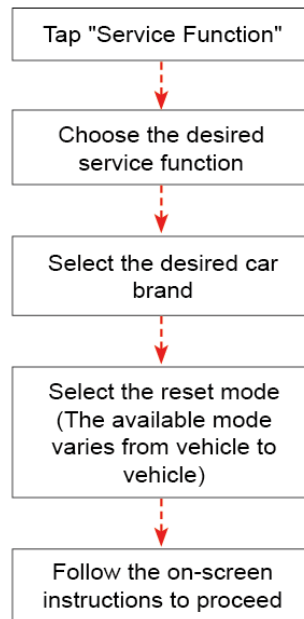

## 7 Software Update

This module enables you to update the diagnostic software & App and frequently used software.

### 7.1 Update Diagnostic Software & APP

Go to **Software Update** on the Job Menu and tap the **Downloaded** tab.

The **Available** tab displays a list of software that can be updated. Under it, all software is categorized into three kinds:

- **Common software:** mainly includes some common apps that are associated with the diagnostic app. The software of this kind always stays at the top of the list, which can be deselected manually (excluding the system app, such as firmware and ECU aid).
- **Frequently used vehicle software:** refers to the diagnostic software that is frequently used, including the vehicle diagnostic software and Reset software. It is generally displayed following the **Common software** list.
- **Other vehicle software:** refers to the diagnostic software that is rarely used or never used. It is generally displayed following the **Frequently used software** list.

- 1). If the user does not download any diagnostic software during the sign-up process, all diagnostic software is selected by default. Tap **Update** to start downloading.
- 2). If the user downloaded all/some vehicle software during the sign-up process and had it serviced for a long period of time, only the frequently used software is selected. Tap **Update** to start downloading. Other vehicle software that is rarely used will also be listed under the **Available** tab, but it is not selected at default.

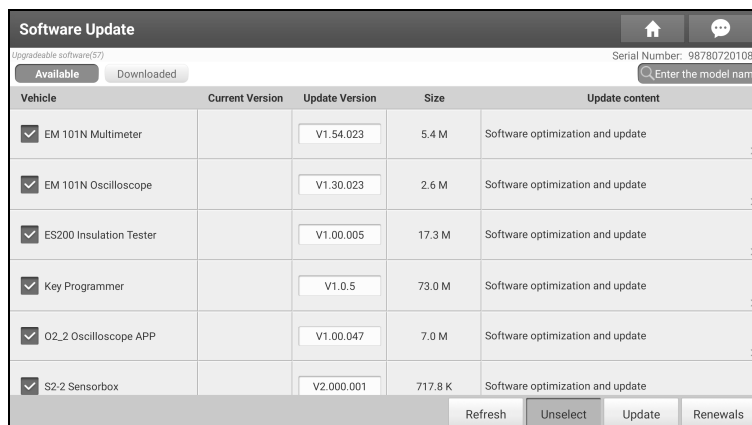

To download certain software that is not frequently used, check the box before the vehicle model. Tap **Update** to start downloading.

Once download is finished, the software packages will be installed automatically.

### 7.2 Update Frequently Used software

If the user only intends to update the frequently used software, go to Software Update and tap the **Downloaded** tab.

Tap **Update** to start downloading. Once download is finished, the software packages will be installed automatically.

### 7.3 Renew Subscription

If the software subscription is due or expires, the system will prompt you to renew your subscription.

Tap **Renewal** on the bottom of the screen to enter the **Mail** to renew the subscription.

## 8 Toolbox

This function includes the following add-on modules: TPMS, ADAS, Oscilloscope, Sensor simulator, BST360 Battery Tester, Immobilizer programmer, Videoscope, Current clamp, Multimeter, Insulation Tester, Key programmer and more. Each module consists of two parts: hardware and app. These modules cannot work properly on the tablet, which need to work with the specific compatible hardware (sold separately). For detailed operations, refer to the User Manual of each module.

### 8.1 TPMS

This module allows you to configure the tablet as TPMS activation & diagnostic tool, which provides the ability to trigger TPMS sensor, program TPMS sensor, perform the relearning procedure. It needs to work with the compatible TSGUN device (sold separately).

For more details, please refer to the User Manual included with the module.

### 8.2 ADAS (Calibration)

This module enables you to effectively and accurately calibrate a wide range of camera-based & radar-based driver assistance systems, e.g. the front camera for the lane departure warning system, the radar sensor for the ACC (Adaptive Cruise Control) or the camera for adaptive headlights. It needs to work with the specific ADAS calibration tool (sold separately).

For more details, please refer to the User Manual included with the module.

### 8.3 Oscilloscope

This module can make the auto repair technician quickly judge the faults on automotive electronic equipment and wiring. It needs to work with the specific Scopebox (sold separately).

For more details, please refer to the User Manual included with the module.

### 8.4 Sensor Simulator

This module is specially designed to diagnose and simulator vehicle sensor faults quickly and conveniently. It needs to work with the compatible S2-2 Sensorbox (sold separately).

For more details, please refer to the User Manual included with the module.

### 8.5 BST360 (Battery Tester)

This module allows you to fix battery detection faster and easier. It needs to work with the specific Bluetooth battery tester (sold separately).

For more details, please refer to the User Manual included with the module.

### 8.6 Immobilizer Programmer

This module allows you to perform the read-write function for vehicle keys, EEPROM, MCU, and EEPROM/FLASH of vehicle engine and gearbox ECU. It needs to work with the specific immobilizer programmer (sold separately).

For more details, please refer to the User Manual included with the module.

### 8.7 Videoscope

This module allows you to check those unseen parts of engine, fuel tank, and braking system etc. It needs to work with the compatible Videoscope (sold separately).

For more details, please refer to the User Manual included with the module.

### **8.8 Current Clamp**

This module allows you to perform AC/DC current test and DC voltage test for traditional fuel cars and new energy vehicles. It needs to work with the compatible current clamp (sold separately).

For more details, please refer to the User Manual included with the module.

### **8.9 Insulation Tester**

The function enables you to complete the measurement of insulation resistance, voltage and other parameters. It is suitable for users who measure and overhaul on-site power equipment and power supply lines.

For more details, please refer to the User Manual included with the module.

### **8.10 Multimeter**

This module allows you to measure the physical parameters such as voltage, resistance, frequency etc. It utilizes the same hardware as the EM101N.

For more details, please refer to the User Manual included with the EM101N.

### **8.11 Key Programmer**

The function can identify car key chips and generate various types of chip models from super remotes, read the remote control frequency of car keys, and generate remote control devices for different car models from various types of super remotes. It needs to work with the compatible key programmer (sold separately).

For more details, please refer to the User Manual included with the module.



## 9 Diagnostic Widget

### 9.1 Vehicle Coverage

Use this item to check which vehicle models are supported on the tool.

### 9.2 CAN Bus Pin Detection

This function allows you to detect the voltage of the vehicle OBD II diagnostic socket pins and the supported protocol types to help technicians judge the OBD II diagnostic interface.

### 9.3 CANScope

This item can monitor vehicle CANBUS data and make it visual on the screen. Moreover it can also check the problems existed in the CAN data, assisting you to analyze fault causes.

### 9.4 Diagnostic Software Clear

This item allows you to hide/clear the diagnostic software that is not frequently used.

 Note: Removing software may completely delete the software from the tablet. If some software is not used and the tablet runs out of space, you can use this feature to remove it. To re-download it, go to **Software Update** -> **Available**.

### 9.5 Fix Connector Firmware/System

Use this item to upgrade and fix VCI firmware/system. During fixing, please do not cut power or switch to other interfaces.

### 9.6 Data Stream Sample

This item allows you to manage the recorded data stream sample files.

### 9.7 DLC Voltage Check

This item performs a check of the vehicle's battery to ensure the system is operating within acceptable limits.

### 9.8 Reset MSVIN

This item can decode the VIN information of all ECUs installed on test vehicle and output all inconsistent VINs.

## 10 User Info

This function allows users to manage personal information and VCI.

### 10.1 My Report

This option is used to view, delete or share the saved reports.

Tap **My Report**, there are total 3 options available.

1). If the DTC result is saved as a diagnostic report on Read Trouble Code page, the report file will be listed under **Health Reports** tab.

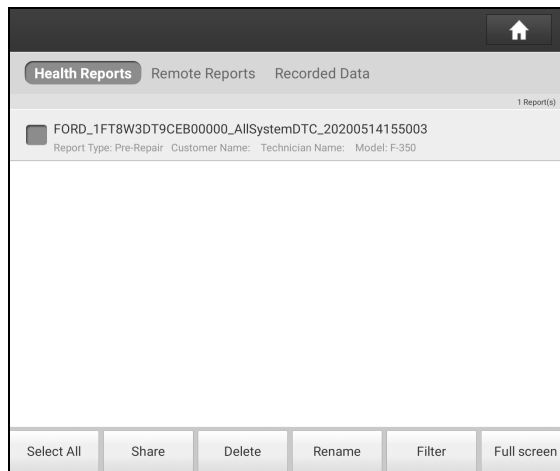

All diagnostic reports are sorted by Date and Make. Tap the desired type to re-arrange and filter it.

- To select certain report, check the box before the report. To select all reports, tap **Select All**. To deselect all, tap **Unselect**.
- To share the report with others, select the desired one and then tap **Share**.
- Select the desired report and then tap **Delete** to delete it.
- To change the filename of report, tap **Rename**.
- To quickly locate the desired report, tap **Filter**.
- To exit the full screen, tap **Exit full screen**.

2). **Remote Reports** lists all diagnostic reports generated in process of remote diagnosis.

3). If user records the running parameters while reading data stream, it will be saved as .x431 file and appear under **Recorded Data** tab.

Tap the desired one to enter. Select the desired data stream items and tap **OK** to jump to the playback page:



### **On-screen Buttons:**

 **Graph** – displays the parameters in waveform graphs.

**Value** – this is the default mode which displays the parameters in texts and shows in list format.

**Combine** – this option is mostly used in graph merge status for data comparison. In this case, different items are marked in different colors.

**Frame Playback** – plays back the recorded data stream items frame by frame. Once it is in frame playback mode, this button changes into **Auto Playback**.

## **10.2 VCI**

This option allows you to manage all your activated VCIs.

If several VCIs are activated on this tool, a list of VCIs will be displayed on the screen. Once you choose the VCI that belongs to other account, you have to log out, and then input the right account to continue.

## **10.3 Activate VCI**

This item lets you activate a new VCI.

## **10.4 Profile**

Use this item to view and configure personal information.

- The profile description includes a 'placeholder' for a user photograph. Tap the user image to change it.
- Tap > next to **Upgrade Period** to check the due date of all diagnostic software.

## **10.5 My Order**

This item allows you to check the status of all your orders.

## **10.6 Change Password**

This item allows you to modify your login password.

## **10.7 Login/Log out**

To logout the current user ID, tap **Log Out**.

To login the system again, tap **Login**.

# 11 Settings

It enables you to make some application settings and view software version information etc.

## 11.1 Units of measurement

It is designed to configure the measurement unit. Metric System and English System are available.

## 11.2 Shop information

This option lets you define your print information. It mainly includes Workshop, Address, Telephone, Fax and License Plate.

Once you saved the print information, it will be entered automatically in the “Add Information” box every time you save the diagnostic report.

## 11.3 Printer set

This option is designed to establish a wireless connection between the tablet and the Wi-Fi printer (sold separately) while performing printing operations.

The App is compatible with the **LAUNCH Wi-Fi Printer** (sold separately) and **System** (external printer).

**For LAUNCH Wi-Fi printer**, refer to the User Manual included with the Wi-Fi printer to configure the printer settings.

**For other Wi-Fi printers**,

Before printing, make sure the following conditions are met:

- The Wi-Fi printer is powered on and working normally.
- The print service plug-in associated with the printer is already installed on the tablet (Go to Google Play or use the Browser to download and install it).

Follow the steps below to proceed:

1. Set the default printer as **System**.
2. Set the Wi-Fi switch to Off.
3. On the report details page, tap .

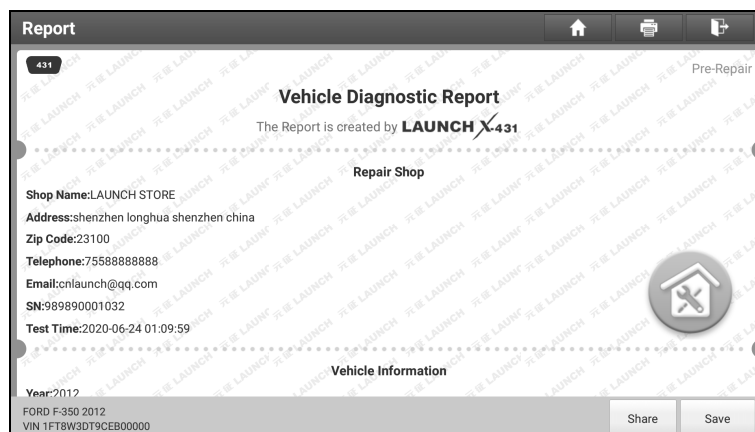

4. Touch  next to **Select a printer** on the upper left corner of the screen.

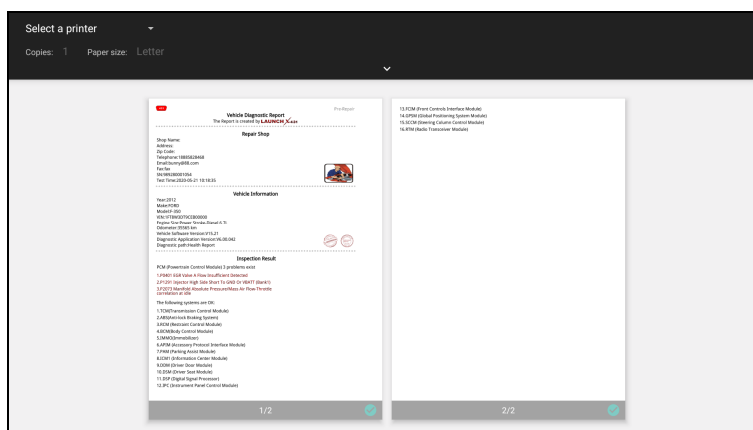

5. Select **All Printers** -> **Add printer** and enable the installed printer service, the system starts searching for all available Wi-Fi printers of the brand.

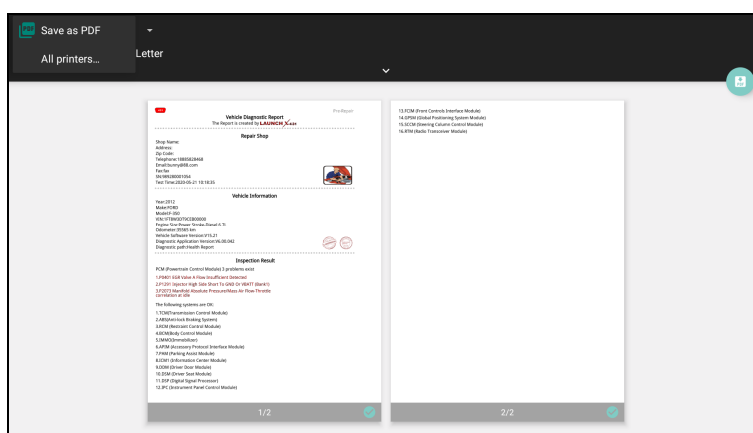

6. Select the desired Wi-Fi printer from the list. If the chosen Wi-Fi printer hotspot is open, the tablet can connect it directly. If it is encrypted, a password may be required. Refer to the Wi-Fi printer user manual to get the default password.
7. Now the printer is ready for printing.
8. Alternatively, you can also choose **Save as PDF** to save the current diagnostic report as a PDF file for later printing.

## 11.4 Clear cache

This item is used to clear the App cache.

Tap **Clear Cache**, a pop-up window will appear on the screen. Tap **OK** to clear cache and the system will restart the App.

## 11.5 About

The software version information and disclaimer are included.

## 11.6 Diagnostic software auto update

This option is used to set whether automatic update function is ON.

## 11.7 Device account management

This option is used to manage the authorized technician accounts. The added technician account allows the VCI to be used by different users to log in the tool, which is convenient for multiple VCIs to perform diagnostic service at the same time.

## LAUNCH

The newly added technician account has a one-year validity period. After the expiration, the VCI bound to the technician account cannot be used and the technician account will no longer enjoy the rights and interests of the main account. The main account can modify the validity period of the sub-account.

There are two types of technician accounts: one is an existing account and the other is a newly created account. The main account has the functions of adding and removing technician accounts, the technician account can also be unbound from the main account.

Tap **Device account management**, the following screen will appear:

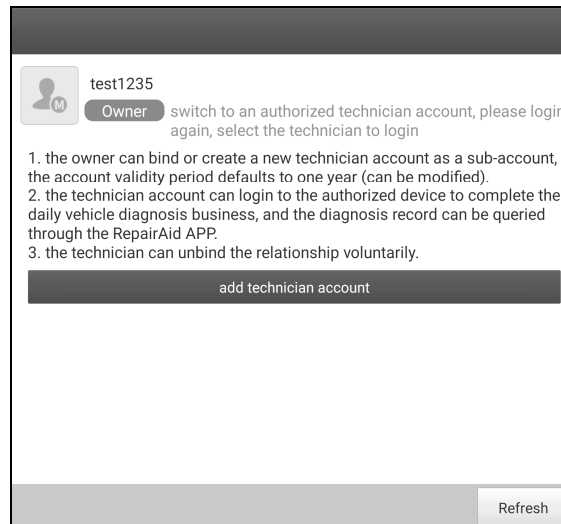

Tap **Add technician account**, the following popup will appear:

- If you already have an account, please enter the user name and password. After inputting, tap **Add Immediately** to add it as an authorized technician account.
- If you have not registered any account, tap **New technician account**. Enter the user name and password, and then tap **Add Immediately** to add it as a technician account.

The new technician account can login the authorized scanner to complete the daily vehicle diagnosis business, and the diagnosis record can be checked through the RepairAid App (can be downloaded in Google Play).

After adding the technician account, tap **Remove** to unbind it from the main account; tap **Change** to revise the validity period.

## 12 J2534 Reprogramming Using SmartLink C

Reprogramming is often the only solution for problems ranging from driveability and loss of power to poor fuel economy and emissions related issues. SmartLink C makes it easy. The SmartLink C is a communication interface designed to support J2534 specifications for ECU reprogramming.

Except that the SmartLink C V3.0 can act as a VCI device and a SmartLink dongle, it also can be used as a J2534 PassThru device, working together with the PC installed with the OEM diagnostic software to perform the J2534 reprogramming. In this case, the PC needs to install with the LAUNCH's J2534 tool, which can be downloaded from the official website at [www.cnlaunch.com](http://www.cnlaunch.com).

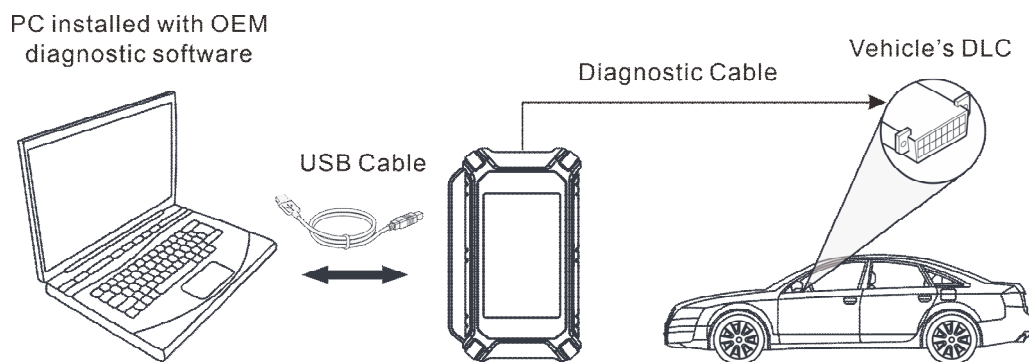

## **13 FAQ**

### **13.1 About diagnostic tablet**

#### **1. How to save power?**

1. Please turn off the screen while the tool keeps idle.
2. Set a shorter standby time.
3. Decrease the brightness of the screen.
4. If WLAN connection is not required, please turn it off.

#### **2. Communication error with vehicle ECU?**

Please confirm:

1. Whether the VCI is correctly connected.
2. Whether ignition switch is ON.
3. If all checks are normal, send vehicle year, make, model and VIN number to us using Feedback feature.

#### **3. Failed to enter into vehicle ECU system?**

Please confirm:

1. Whether the vehicle is equipped with this system.
2. Whether the VCI is correctly connected.
3. Whether ignition switch is ON.
4. If all checks are normal, send vehicle year, make, model and VIN number to us using Feedback feature.

#### **4. How to download the diagnostic App after resetting the tablet?**

 Note: Before registration, please make sure the network is properly connected.

After the tablet has been successfully reset, follow the steps below to download the App:

1. Launch the browser and the default official Launch website opens (If a blank page pops up, just type in [www.x431.com](http://www.x431.com) in the input bar).
2. Tap **Login**, input the username and password and tap **Log In**.
3. Make sure that the serial number is correct, tap **APP application program** and tap the Download icon to start downloading.
4. After the download is complete, follow the on-screen instructions to install it.
5. After installation, use the existing username and password to login and go to update center to download the diagnostic software.

#### **5. What to do if the language of vehicle diagnostic software does not match the system language?**

English is the default system language of the tool. After the system language is set to the preference language, please go to the update center to download the vehicle diagnostic software of the corresponding language.

If the downloaded diagnostic software is still displayed in English, it indicates that the software of the current language is under development.

#### **6. How to retrieve the login password?**

Please follow below steps to proceed in case you forgot the login password:

1. Tap the application icon on the home screen to launch it.
2. Tap the **Login** button on the upper right corner of the screen.
3. Tap **Retrieve password**.



4. Input product S/N and follow the on-screen prompts to retrieve the password.

## **13.2 About SmartLink Diag.**

### **1. What's network conditions is required for SmartLink Diag.?**

The remote SmartLink Diag. operation requires a network broadband of 100MB or above.

### **2. What does the word "Delay" displayed on the SmartLink C screen mean?**

The Delay (network delay) indicates the state of the network communication, which can be regarded as a reference since different vehicles require different delays. Different colors represent different delay status. There are three states of network delay:

**Green:** Indicates a shorter network delay. In this case, it has a higher success rate of remote communication.

**Yellow:** Indicates a medium network delay. In this case, it has a medium success rate of remote communication.

**Red:** Indicates a longer network delay. In this case, it has a lower success rate of remote communication and remote ECU reprogramming operations are not suggested.

### **3. My network delay is so long.**

Please check the following possible reasons:

1. The greater distance between the SmartLink B and SmartLink C dongle causes a longer network delay.
2. There are too many network communication nodes that the data communication passes by, which may cause a longer network delay.
3. Check if the network is poor and data communication speed is slow.

### **4. Some systems of some old vehicles cannot be tested**

The SmartLink C dongle supports CAN2.0/CANFD/DoIP communication protocols, but some old vehicle uses K-Line communication protocol.

### **5. Is it necessary to re-ignite the car after the diagnostic system starts working?**

For the sake of some vehicle's conditions, the re-ignition will provide you a more detailed analysis after OBD diagnosis.



---

## Warranty

THIS WARRANTY IS EXPRESSLY LIMITED TO PERSONS WHO PURCHASE LAUNCH PRODUCTS FOR PURPOSES OF RESALE OR USE IN THE ORDINARY COURSE OF THE BUYER'S BUSINESS.

LAUNCH electronic product is warranted against defects in materials and workmanship for one year from date of delivery to the user.

This warranty does not cover any part that has been abused, altered, used for a purpose other than for which it was intended, or used in a manner inconsistent with instructions regarding use. The exclusive remedy for any automotive meter found to be defective is repair or replacement, and LAUNCH shall not be liable for any consequential or incidental damages.

Final determination of defects shall be made by LAUNCH in accordance with procedures established by LAUNCH. No agent, employee, or representative of LAUNCH has any authority to bind LAUNCH to any affirmation, representation, or warranty concerning LAUNCH automotive meters, except as stated herein.

## Disclaimer

The above warranty is in lieu of any other warranty, expressed or implied, including any warranty of merchantability or fitness for a particular purpose.

## Purchase Order

Replaceable and optional parts can be ordered directly from your LAUNCH authorized tool supplier. Your order should include the following information:

- Order quantity
- Part number
- Part name

## Customer Service

If you have any questions on the operation of the unit, please contact local dealer, or contact **LAUNCH TECH CO., LTD.**:

Website: [www.x431.com](http://www.x431.com)

[www.cnlaunch.com](http://www.cnlaunch.com)

Phone: +86 755 2593 8674

Email: [DOD@cnlaunch.com](mailto:DOD@cnlaunch.com)

## Statement:

LAUNCH reserves the rights to make any change to product designs and specifications without notice. The actual object may differ a little from the descriptions in the manual in physical appearance, color and configuration. We have tried our best to make the descriptions and illustrations in the manual as accurate as possible, and defects are inevitable, if you have any question, please contact local dealer or after-sale service center of LAUNCH, LAUNCH does not bear any responsibility arising from misunderstandings.